

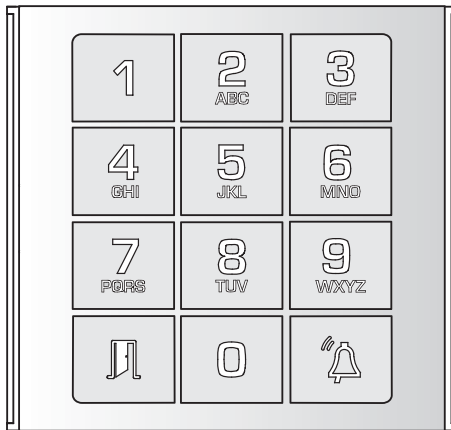

Keypad module

FA01405-EN



MTMKB

INSTALLATION AND PROGRAMMING MANUAL

EN English

General precautions

⚠ **IMPORTANT!** Important safety instructions: READ CAREFULLY!

- Installation, programming, commissioning and maintenance must only be carried out by expert qualified technicians in full compliance with the regulations in force.
- Wear anti-static shoes and clothing if working on the electronic circuit board.
- Keep this precaution information.
- Disconnect the power supply during any cleaning or maintenance work.
- The product must only be used for the purpose for which it was expressly designed. Any other use is to be considered dangerous.
- The manufacturer declines all liability for any damage as a result of improper, incorrect or unreasonable use.
- This device complies with Part 15 of the FCC Rules. Operation is subject to the following two conditions:
 - 1 - This device may not cause harmful interference.
 - 2 - This device must accept any interference received, including interference that may cause undesired operation.

DESCRIPTION

Keypad module connectible on BUS.

⚠ Assembly and removal of the module must take place with no power to the entry panel.

❶ Sockets for the connector to connect additional modules.

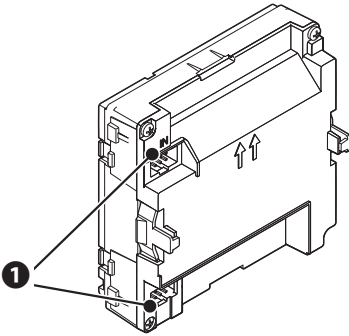

Technical data

Type	MTMKB
Power supply (V DC)	10.7 to 18
MAX consumption (mA)	55
MIN consumption (mA)	5
Storage temperature (°C)	-25 to +70
Operating temperature (°C)	-25 to +55
Protection rating (IP)	54

NUMBERING OF CALL KEYS

Organisation of call codes where there are call keys

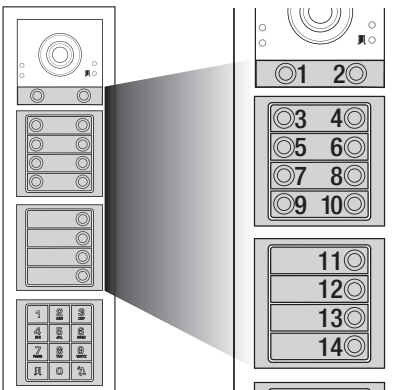

In manual programming the call keys are arranged as in the diagram for a maximum of 98 keys.

In this way, for example, pressing key 6 corresponds to entering number 6 on the MTMKB keypad followed by key ⚠.

PROGRAMMING CALL CODES AND DOOR-RELEASE CODES

i This programming is available only with audio modules MTMA/01 and video modules MTMV/01. Call programming associates a call code with each internal receiver.

Programming the door-release codes associates number codes with the relays present on audio module MTMA/01 or video module MTMV/01. The control is local and where there is more than one audio module MTMA/01 and video module MTMV/01 carry out the door-release programming on each entry panel.

Going into Programming

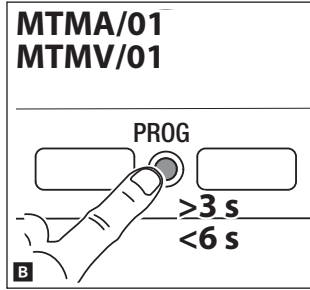
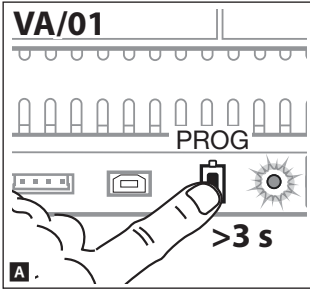

With VA/01

Press the PROG key until the PROG LED lights up **A**.

With MTMA/01-MTMV/01 with-out VA/01



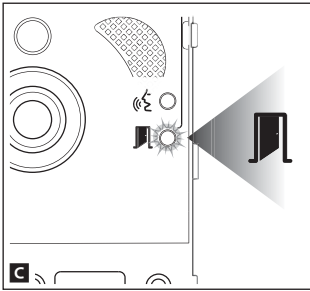

Press the PROG key for at least 3 seconds and release it within 6 seconds **B**.



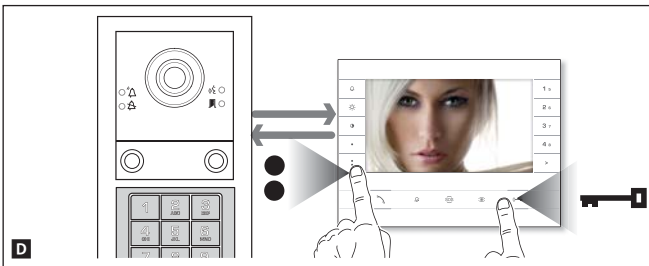

The  LED will flash to signal entry into programming **C**.

Programming the call codes

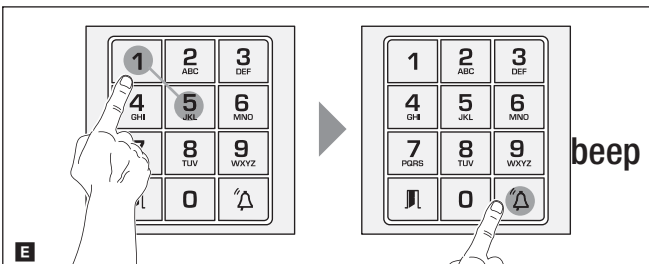

Press the door-release  and AUX2  keys and enter the group call code (from 1 to 98) followed by key . The call code is associated with the internal receiver **D** and the call key chosen **E**. Continue, repeating the same operations for all the other internal receivers. The operation can only be carried out from an entry panel with the  LED off.





i To change the entry panel from which to carry out call programming, you must press key 1 followed by key .

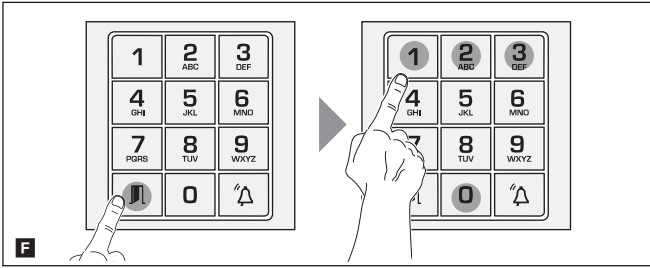

Programming door-release codes and relay codes

This procedure lets you associate codes with the relays on the audio module MTMA/01, the video module MTMV/01, or on any eventual VLS/2.

For example, you can open the front door with a code, or switch on the stairwell lighting with another code.



Press the  key and 0, 1, 2 or 3 to identify the relay (see table).

Press key  and the code to be associated (from 3 to 5 digits) with the relay. Press key  again: a beep will confirm the relay association procedure **G**.

Key Command

0	Auxiliary contact
1	Door release contact
2	Relay 1 on module VLS/2
3	Relay 2 on module VLS/2

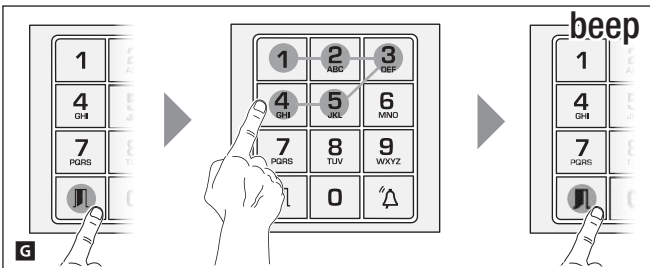

i The door-release and relay code programming procedure deletes all the previously programmed codes.

Exiting Programming

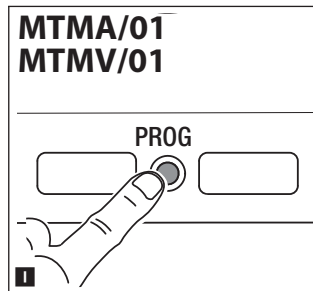
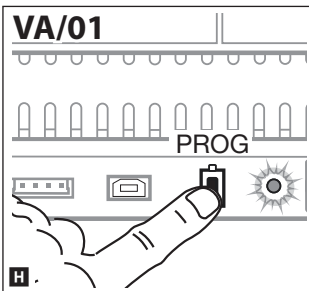

With VA/01

Briefly press the PROG key **H**.

With MTMA/01-MTMV/01 without VA/01

Briefly press the PROG key on the entry panel **I**.

The  LED on the entry panel and the PROG LED on the power supply go out.

PROGRAMMING THE CALL CODES

i This programming is available only with audio module MTMA/08 and video module MTMV/08.
Call programming associates a call code with each internal receiver.

Going into Programming

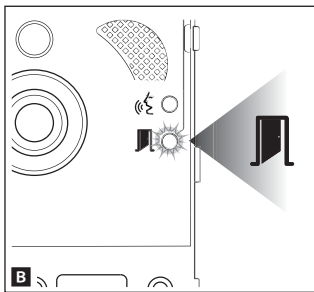
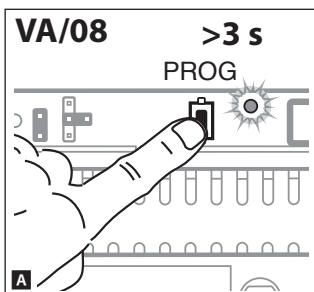



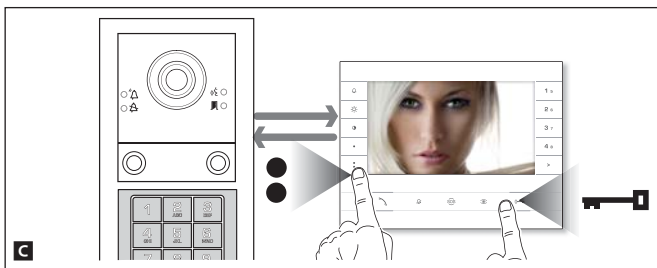

Press the PROG key until the PROG LED lights up **A**.

The  LED will flash to signal entry into programming **B**.

Programming the call codes



Press the door-release  and AUX2  keys and enter the group call code (from 1 to 98) followed by key . The call code is associated with the internal receiver or the call key chosen **C** and **D**.

Continue, repeating the same operations for all the other internal receivers. The operation can only be carried out from the entry panel with the  LED off.

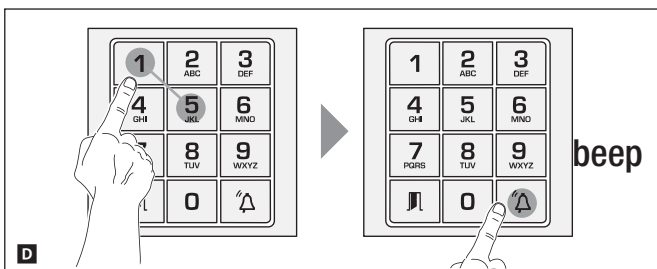

i To change the entry panel from which to carry out call programming, you must press key 1 followed by key .

Exiting Programming

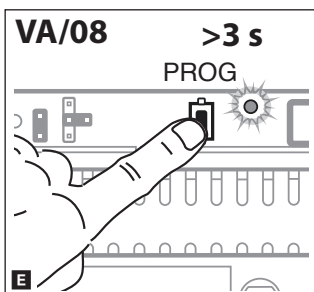

Briefly press the PROG key **E**.

The  LED on the entry panel and the PROG LED on the power supply go out.

PROGRAMMING ACCESS CONTROL NUMBER CODES

This procedure lets you associate number codes with a group of users, or remove them, for control of door release in audio module MTMA/01, MTMA/08 and video module MTMV/01, MTMV/08.
A maximum of 5 number codes can be associated per group.

Adding number codes

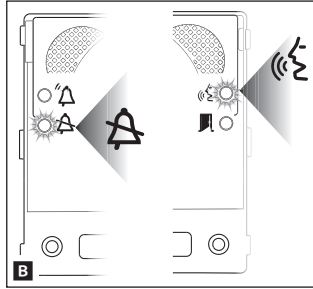
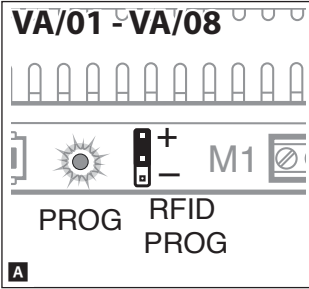

Put the RFID PROG jumper in the "+" position. The PROG LED on the power supply and the and LEDs will flash quickly **A** and **B**.

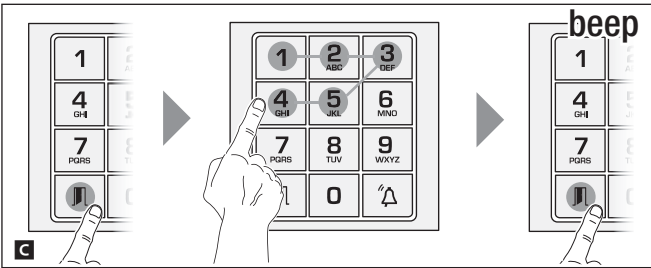

Press key **C**, enter the access code (4 to 8 digits long) followed by key **D**. If the code is valid, the LED stays constantly on and it is possible to continue with programming. Enter the group call code, or press the call key associated with the group, followed by key **D**. A long beep will confirm the procedure was correct.

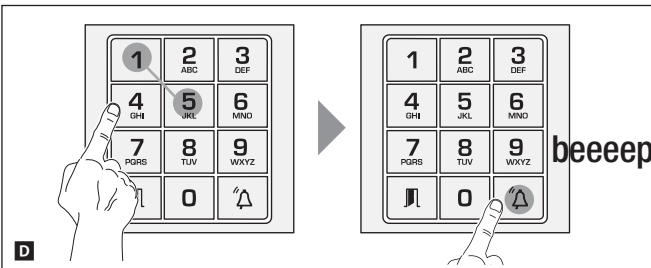

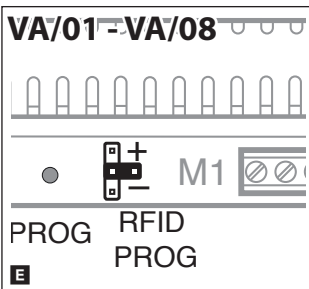

i In the event of an error, this will be indicated by 3 fast beeps. Repeat the stage correctly.



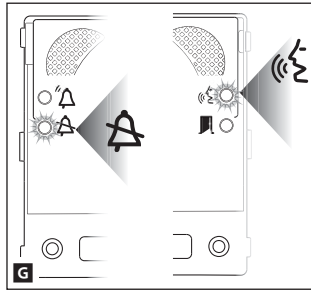
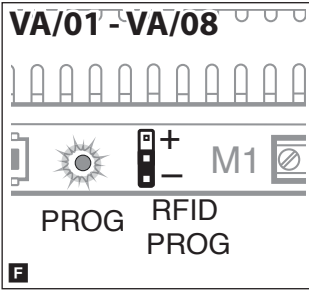

When programming is completed, place the RFID PROG jumper as shown in figure **E**.

Deleting number codes



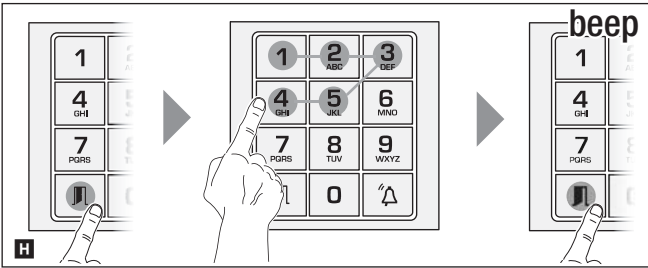

Put the RFID PROG jumper in the “-” position. The PROG LED on the power supply and the  and  LEDs will flash slowly **F** and **G**.





To delete the number codes relating to a group, press , enter an access code (4 to 8 digits long) associated with the group, followed by key  **H**.

If the code is valid, the  LED stays constantly on and it is possible to continue with programming.

Press key , enter the access code again and press key  again to confirm the operation. A long beep will confirm the procedure was correct.

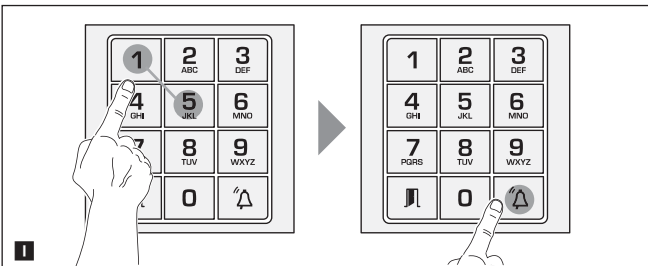
i In the event of an error, this will be indicated by 3 fast beeps. Repeat the stage correctly.



To delete all the codes relating to a group, enter the call code, or press the call key associated with the group, followed by key  **I**.

If the code is valid, the  LED stays constantly on and it is possible to continue with programming.

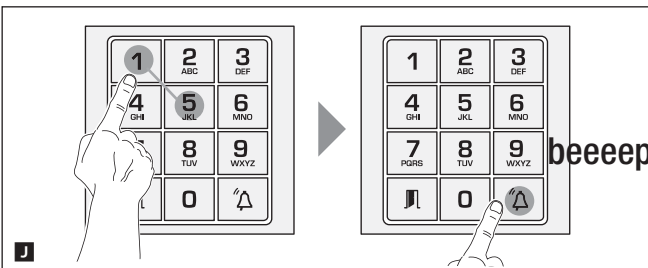

Enter the call code again, or press the call key associated with the group, followed by key  **J**. A long beep will confirm the procedure was correct.

i In each of the two stages of deletion any error condition will be signalled by three fast beeps. Repeat the stage correctly.

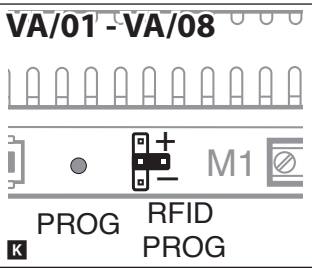

When programming is completed, place the RFID PROG jumper as shown in figure **K**.

USE OF KEYPAD MODULE

Used as access control

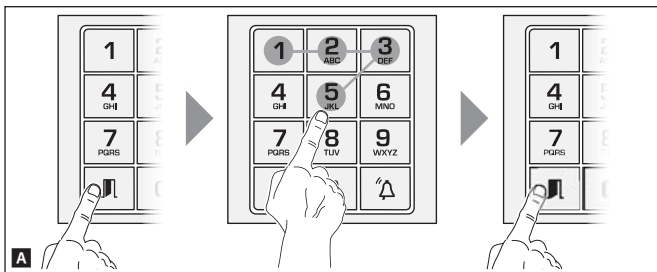

Press key **7**, enter the access code (3 to 8 digits long) and press key **7** again: if the code is valid a confirmation beep will sound and the **7** LED will come on, otherwise 3 fast beeps will signal an error condition **A**.

Used to make calls

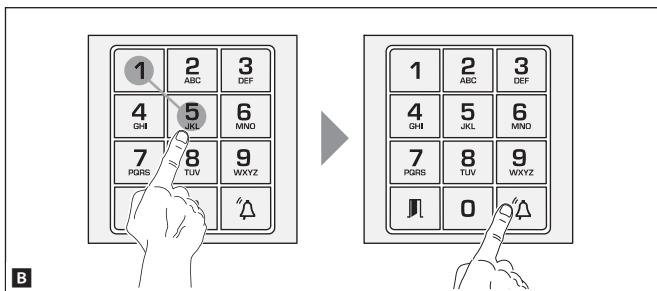

Enter the call code (1-98), followed by key **0**: if the code is valid the call will be made and the **0** LED will come on **B**.

This product complies with the relevant directives in force.

Decommissioning and disposal. Dispose of the packaging and the device at the end of its life cycle responsibly, in compliance with the laws in force in the country where the product is used. The recyclable components are marked with a symbol and the material's ID marker.

THE DATA AND INFORMATION SHOWN IN THIS MANUAL ARE TO BE CONSIDERED AS SUBJECT TO CHANGE AT ANY TIME AND WITHOUT THE NEED FOR ANY ADVANCE WARNING.

MEASUREMENTS, UNLESS OTHERWISE INDICATED, ARE IN MILLIMETRES.

CAME 
BPT

CAME.COM

CAME S.P.A.

Via Martiri Della Libertà, 15
31030 Dosson di Casier - Treviso - Italy
tel. (+39) 0422 4940 - fax. (+39) 0422 4941