

Sur-Gard SG-System III Multi-Platform Receiver



Installation and Operating Manual

WARNING: This manual contains information on limitations regarding product use and function and information on the limitations as to liability of the manufacturer. The entire manual should be carefully read.

version 2.0

WARNING Please Read Carefully

Note to Installers

This warning contains vital information. As the only individual in contact with system users, it is your responsibility to bring each item in this warning to the attention of the users of this system.

System Failures

This system has been carefully designed to be as effective as possible. There are circumstances, however, involving fire, burglary, or other types of emergencies where it may not provide protection. Any alarm system of any type may be compromised deliberately or may fail to operate as expected for a variety of reasons. Some but not all of these reasons may be:

■ Inadequate Installation

A security system must be installed properly in order to provide adequate protection. Every installation should be evaluated by a security professional to ensure that all access points and areas are covered. Locks and latches on windows and doors must be secure and operate as intended. Windows, doors, walls, ceilings and other building materials must be of sufficient strength and construction to provide the level of protection expected. A reevaluation must be done during and after any construction activity. An evaluation by the fire and/or police department is highly recommended if this service is available.

■ Criminal Knowledge

This system contains security features which were known to be effective at the time of manufacture. It is possible for persons with criminal intent to develop techniques which reduce the effectiveness of these features. It is important that a security system be reviewed periodically to ensure that its features remain effective and that it be updated or replaced if it is found that it does not provide the protection expected.

■ Access by Intruders

Intruders may enter through an unprotected access point, circumvent a sensing device, evade detection by moving through an area of insufficient coverage, disconnect a warning device, or interfere with or prevent the proper operation of the system.

■ Power Failure

Control units, intrusion detectors, smoke detectors and many other security devices require an adequate power supply for proper operation. If a device operates from batteries, it is possible for the batteries to fail. Even if the batteries have not failed, they must be charged, in good condition and installed correctly. If a device operates only by AC power, any interruption, however brief, will render that device inoperative while it does not have power. Power interruptions of any length are often accompanied by voltage fluctuations which may damage electronic equipment such as a security system. After a power interruption has occurred, immediately conduct a complete system test to ensure that the system operates as intended.

■ Failure of Replaceable Batteries

This system's wireless transmitters have been designed to provide several years of battery life under normal conditions. The expected battery life is a function of the device environment, usage and type. Ambient conditions such as high humidity, high or low temperatures, or large temperature fluctuations may reduce the expected battery life. While each transmitting device has a low battery monitor which identifies when the batteries need to be replaced, this monitor may fail to operate as expected. Regular testing and maintenance will keep the system in good operating condition.

■ Compromise of Radio Frequency (Wireless) Devices

Signals may not reach the receiver under all circumstances which could include metal objects placed on or near the radio path or deliberate jamming or other inadvertent radio signal interference.

■ System Users

A user may not be able to operate a panic or emergency switch possibly due to permanent or temporary physical disability, inability to reach the device in time, or unfamiliarity with the correct operation. It is important that all system users be trained in the correct operation of the alarm system and that they know how to respond when the system indicates an alarm.

■ Smoke Detectors

Smoke detectors that are a part of this system may not properly alert occupants of a fire for a number of reasons, some of which follow. The smoke detectors may have been improperly installed or positioned. Smoke may not be able to reach the smoke detectors, such as when the fire is in a chimney, walls or roofs, or on the other side of closed doors. Smoke detectors may not detect smoke from fires on another level of the residence or building.

Every fire is different in the amount of smoke produced and the rate of burning. Smoke detectors cannot sense all types of fires equally well. Smoke detectors may not provide timely warning of fires caused by carelessness or safety hazards such as smoking in bed, violent explosions, escaping gas, improper storage of flammable materials, overloaded electrical circuits, children playing with matches or arson.

Even if the smoke detector operates as intended, there may be circumstances when there is insufficient warning to allow all occupants to escape in time to avoid injury or death.

■ Motion Detectors

Motion detectors can only detect motion within the designated areas as shown in their respective installation instructions. They cannot discriminate between intruders and intended occupants. Motion detectors do not provide volumetric area protection. They have multiple beams of detection and motion can only be detected in unobstructed areas covered by these beams. They cannot detect motion which occurs behind walls, ceilings, floor, closed doors, glass partitions, glass doors or windows. Any type of tampering whether intentional or unintentional such as masking, painting, or spraying of any material on the lenses, mirrors, windows or any other part of the detection system will impair its proper operation.

Passive infrared motion detectors operate by sensing changes in temperature. However their effectiveness can be reduced when the ambient temperature rises near or above body temperature or if there are intentional or unintentional sources of heat in or near the detection area. Some of these heat sources could be heaters, radiators, stoves, barbecues, fireplaces, sunlight, steam vents, lighting and so on.

■ Warning Devices

Warning devices such as sirens, bells, horns, or strobes may not warn people or waken someone sleeping if there is an intervening wall or door. If warning devices are located on a different level of the residence or premise, then it is less likely that the occupants will be alerted or awakened. Audible warning devices may be interfered with by other noise sources such as stereos, radios, televisions, air conditioners or other appliances, or passing traffic. Audible warning devices, however loud, may not be heard by a hearing-impaired person.

■ Telephone Lines

If telephone lines are used to transmit alarms, they may be out of service or busy for certain periods of time. Also an intruder may cut the telephone line or defeat its operation by more sophisticated means which may be difficult to detect.

■ Insufficient Time

There may be circumstances when the system will operate as intended, yet the occupants will not be protected from the emergency due to their inability to respond to the warnings in a timely manner. If the system is monitored, the response may not occur in time to protect the occupants or their belongings.

■ Component Failure

Although every effort has been made to make this system as reliable as possible, the system may fail to function as intended due to the failure of a component.

■ Inadequate Testing

Most problems that would prevent an alarm system from operating as intended can be found by regular testing and maintenance. The complete system should be tested weekly and immediately after a break-in, an attempted break-in, a fire, a storm, an earthquake, an accident, or any kind of construction activity inside or outside the premises. The testing should include all sensing devices, keypads, consoles, alarm indicating devices and any other operational devices that are part of the system.

■ Security and Insurance

Regardless of its capabilities, an alarm system is not a substitute for property or life insurance. An alarm system also is not a substitute for property owners, renters, or other occupants to act prudently to prevent or minimize the harmful effects of an emergency situation.

Limited Warranty

Digital Security Controls warrants the original purchaser that for a period of twelve months from the date of purchase, the product shall be free of defects in materials and workmanship under normal use. During the warranty period, Digital Security Controls shall, at its option, repair or replace any defective product upon return of the product to its factory, at no charge for labour and materials. Any replacement and/or repaired parts are warranted for the remainder of the original warranty or ninety (90) days, whichever is longer. The original purchaser must promptly notify Digital Security Controls in writing that there is defect in material or workmanship, such written notice to be received in all events prior to expiration of the warranty period. There is absolutely no warranty on software and all software products are sold as a user license under the terms of the software license agreement included with the product. The Customer assumes all responsibility for the proper selection, installation, operation and maintenance of any products purchased from DSC. Custom products are only warranted to the extent that they do not function upon delivery. In such cases, DSC can replace or credit at its option.

International Warranty

The warranty for international customers is the same as for any customer within Canada and the United States, with the exception that Digital Security Controls shall not be responsible for any customs fees, taxes, or VAT that may be due.

Warranty Procedure

To obtain service under this warranty, please return the item(s) in question to the point of purchase. All authorized distributors and dealers have a warranty program. Anyone returning goods to Digital Security Controls must first obtain an authorization number. Digital Security Controls will not accept any shipment whatsoever for which prior authorization has not been obtained.

Conditions to Void Warranty

This warranty applies only to defects in parts and workmanship relating to normal use. It does not cover:

- damage incurred in shipping or handling;
- damage caused by disaster such as fire, flood, wind, earthquake or lightning;
- damage due to causes beyond the control of Digital Security Controls such as excessive voltage, mechanical shock or water damage;
- damage caused by unauthorized attachment, alterations, modifications or foreign objects;
- damage caused by peripherals (unless such peripherals were supplied by Digital Security Controls);
- defects caused by failure to provide a suitable installation environment for the products;
- damage caused by use of the products for purposes other than those for which it was designed;
- damage from improper maintenance;
- damage arising out of any other abuse, mishandling or improper application of the products.

Items Not Covered by Warranty

In addition to the items which void the Warranty, the following items shall not be covered by Warranty: (i) freight cost to the repair centre; (ii) products which are not identified with DSC's product label and lot number or serial number; (iii) products disassembled or repaired in such a manner as to adversely affect performance or prevent adequate inspection or testing to verify any warranty claim. Access cards or tags returned for replacement under warranty will be credited or replaced at DSC's option. Products not covered by this warranty, or otherwise out of warranty due to age, misuse, or damage shall be evaluated, and a repair estimate shall be provided. No repair work will be performed until a valid purchase order is received from the Customer and a Return Merchandise Authorisation number (RMA) is issued by DSC's Customer Service.

Digital Security Controls's liability for failure to repair the product under this warranty after a reasonable number of attempts will be limited to a replacement of the product, as the exclusive remedy for breach of warranty. Under no circumstances shall Digital Security Controls be liable for any special, incidental, or consequential damages based upon breach of warranty, breach of contract, negligence, strict liability, or any other legal theory. Such damages include, but are not limited to, loss of profits, loss of the product or any associated equipment, cost of capital, cost of substitute or replacement equipment, facilities or services, down time, purchaser's time, the claims of third parties, including customers, and injury to property. The laws of some jurisdictions limit or do not allow the disclaimer of consequential damages. If the laws of such a jurisdiction apply to any claim by or against DSC, the limitations and disclaimers contained here shall be to the greatest extent permitted by law. Some states do not allow the exclusion or limitation of incidental or consequential damages, so that the above may not apply to you.

Disclaimer of Warranties

This warranty contains the entire warranty and shall be in lieu of any and all other warranties, whether expressed or implied (including all implied warranties of merchantability or fitness for a particular purpose) And of all other obligations or liabilities on the part of Digital Security Controls Digital Security Controls neither assumes responsibility for, nor authorizes any other person purporting to act on its behalf to modify or to change this warranty, nor to assume for it any other warranty or liability concerning this product.

This disclaimer of warranties and limited warranty are governed by the laws of the province of Ontario, Canada.

WARNING: Digital Security Controls recommends that the entire system be completely tested on a regular basis. However, despite frequent testing, and due to, but not limited to, criminal tampering or electrical disruption, it is possible for this product to fail to perform as expected.

Installer's Lockout

Any products returned to DSC which have the Installer's Lockout option enabled and exhibit no other problems will be subject to a service charge.

Out of Warranty Repairs

Digital Security Controls will at its option repair or replace out-of-warranty products which are returned to its factory according to the following conditions. Anyone returning goods to Digital Security Controls must first obtain an authorization number. Digital Security Controls will not accept any shipment whatsoever for which prior authorization has not been obtained.

Products which Digital Security Controls determines to be repairable will be repaired and returned. A set fee which Digital Security Controls has predetermined and which may be revised from time to time, will be charged for each unit repaired.

Products which Digital Security Controls determines not to be repairable will be replaced by the nearest equivalent product available at that time. The current market price of the replacement product will be charged for each replacement unit.

Table of Contents

Section 1 - Introduction	1	4.3 Debug	13
1.1 System Overview	1	4.4 Manual Programming	13
1.2 Approvals	1	4.5 SG-CPM3 Options	14
1.3 Description (Hardware)	3	Section 5 - Advanced Programming	20
1.4 Receiver Setup and Operation	8	5.1 Profiles Introduction	20
1.5 Description (Operation)	8	5.2 SG-DRL3-2L System Options: [00] - [2F]	21
Section 2 - SG-CPM3 Operating Modes	10	5.3 SG-DRL3/SG-DRL3-2L Static Options: [00] - [2F]	21
2.1 Contrast Adjust	10	5.4 SG-DRL3/SG-DRL3-2L Dynamic Options: [30]/[130]/[230] -	
2.2 Active Mode	10	[3F]/[13F]/[23F]	25
2.3 Manual Mode	10	Section 6 - SG-DRL3-IP Programming	36
2.4 Standby Mode	10	6.1 Options: [00] - [47]	36
2.5 System Trouble and System Information	10	Glossary	38
2.6 AHS Table Management	10	Appendix A - Printer Words: Options [60-6F]	41
Section 3 - Line Card Operating Modes	11	Appendix B - TELCO Connector Pin-outs	43
3.1 Standby Mode	11	Appendix C - DEC-HEX-BIN Conversion Chart	44
3.2 Line Fault	11	Appendix D - ASCII Character Chart	45
3.3 SG-CPM3 Error	11	Appendix E - SG-DRL3 Communication Formats	46
3.4 SG-DRL3/SG-DRL3-2L Data Reception	11		
Section 4 - Programming/Operation	13		
4.1 Introduction	13		
4.2 Console Software	13		

GENERAL DESCRIPTION of the EQUIPMENT and CLASSIFICATION.

CLASSIFICATION

The SYSTEM III equipment is a CLASS 1, RACK-MOUNTED, (FIXED – STATIONARY) EQUIPMENT, PLUGGABLE TYPE A USING A DETACHABLE POWER SUPPLY CORD, designed to be INSTALLED, OPERATED and MAINTAINED by SERVICE PERSONNEL ONLY - [persons having appropriate technical training and experience necessary to be aware of hazards to which they are exposed in performing a task and of measures to minimise the danger to themselves or other persons].

The equipment SYSTEM III is designed to be installed in RESTRICTED ACCESS LOCATIONS within an environment that provides the Pollution Degree max 2 and OVERVOLTAGES CATEGORY II - NONHAZARDOUS LOCATIONS, INDOOR ONLY.

The POWER SUPPLY CORD serves as a means of disconnection from the MAINS. The OUTLET used to power the equipment shall be installed near the equipment and shall be easily accessible. The equipment must be connected to a socket-outlet with a protective earthing connection! The INSTALLATION of the SYSTEM III equipment must provide a reliable earth connection and it shall respect the local electrical wiring regulations.

IMPORTANT:

IT IS THE RESPONSIBILITY OF THE INSTALLER TO ENSURE THAT THE SYSTEM III EQUIPMENT IS PROPERLY MOUNTED WITHIN A METALLIC FIRE ENCLOSURE WITH A MINIMUM THICKNESS OF 1.5 MM AND THE FINAL ASSEMBLY IS COMPLIANT WITH ALL OF THE APPLICABLE REQUIREMENTS FROM THE POINT OF VIEW OF THE ACCESSIBILITY TO THE ENERGIZED PARTS (HAZARDOUS VOLTAGES, TNV CIRCUITS, ETC.) AS THESE CHARACTERISTICS ARE DEFINED WITHIN THE EN60950-1: 2006 STANDARD.

THE EXTERNAL ENCLOSURE SHALL MEET ALL OF THE APPLICABLE REQUIREMENTS FROM THE POINT OF VIEW OF PHYSICAL REQUIREMENTS, E.G.: STEADY FORCE 250N, IMPACT AND STABILITY. THE EQUIPMENT MUST BE SECURED TO THE BUILDING STRUCTURE BEFORE OPERATION; ALL WIRING AND INSTALLATION SHALL BE IN ACCORDANCE WITH ELECTRICAL CODES ACCEPTABLE TO THE AUTHORITIES THAT HAVE JURISDICTION WHERE THE EQUIPMENT IS INSTALLED, SERVICED AND OPERATED.

NOT MORE THAN 3 (THREE) ASSEMBLIES [EACH CONSISTING OF 2 (TWO) SG-SYSTEM III EQUIPMENT] MOUNTED WITHIN THE SAME RACK SHALL BE POWERED FROM THE SAME BRANCH CIRCUIT. USE A DIFFERENT BRANCH CIRCUIT FOR ANY GROUP LARGER THAN 3 (THREE) ASSEMBLIES.

The rack must be FIXED in place; The subassemblies shall NOT BE EXTENDED AWAY from the rack for installation and/or any other purpose.

Internal wiring shall be routed in a manner that prevents:

- excessive strain on wire and on terminal connections;
- loosening of terminal connections;
- damage of conductor insulation.

The wireways within the enclosure shall be smooth and free from sharp edges. Wires shall be protected and routed so that they do not come in contact with burrs, cooling fan or heatsinks which could cause damage to the insulation of conductors. Holes in metal shall have smooth well-rounded surfaces or shall be protected with bushings.

The EXTERNAL ENCLOSURE shall be connected to the PROTECTIVE EARTH GROUND. The external cabinet (RACK) must be secured to the building structure before operation in a such a way to fully meet the STABILITY REQUIREMENTS as per EN60950-1: 2006 conditions.

An adequate MARKING [visible before the door (cover)], NEXT TO THE ACCESS DOOR (or cover) of the rack, with instructions for protection once the DOOR (or covers) IS (are) removed, stating that “telephone cord is to be disconnected prior to opening the door” is an example of an acceptable Marking), and it shall be provided by the Installer.

An acceptable power supply cord (detachable), shall be used accordingly to the local outlets and voltages. IT IS THE INSTALLER'S RESPONSIBILITY TO PROVIDE AN APPROPRIATE ACCEPTABLE POWER SUPPLY CORD.

CAUTION:

This product uses Lithium Batteries. Improper handling of lithium batteries may result in HEAT GENERATION, EXPLOSION or FIRE, which may lead to personal injuries.

Please ensure that the above precautions are strictly observed by the related divisions including but not limited to sales, service, customers and (or) outside contractors.

THE EQUIPMENT SYSTEM III IS EQUIPPED WITH LITHIUM NON REPLACEABLE BATTERY. DO NOT ATTEMPT TO REPLACE THE BATTERY.

CONNECTION TO THE MAINS

1. Connect first the DETACHABLE POWER SUPPLY CORD to the IEC 320 connector located on SYSTEM III equipment.
2. Connect all the telecommunications cord-sets to the appropriate connectors.
3. Be sure that the enclosure of the equipment SYSTEM III is fully installed (covers, doors, etc.) in a such a way that HAZARDOUS VOLTAGES and TNV Circuits will not be ACCESSIBLE when the equipment will be connected to the MAINS and/or TELECOMMUNICATION NETWORK.

ATTENTION: THE INTERNAL POWER SUPPLIES ARE NOT SWAPPABLE! DISCONNECT POWER BEFORE ATTEMPTING TO CHANGE A POWER SUPPLY!

In order to change the INTERNAL Power Supply, first DISCONNECT the DETACHABLE POWER SUPPLY CORD from the socket outlet used to provide power, and then, from the IEC320 Connector which is mounted on the SYSTEM III equipment. Wait minimum 5 seconds to allow the Capacitor (C8) within the unit to discharge. IF THE FUSE IS SUSPECTED OF HAVING OPENED, a discharge path for the involved Capacitor (C8) shall be provided.

Do not touch the HEATSINKS within the equipment: these are LIVE PARTS and/or may present a hazard related to high temperatures. In order to swap the boards USE THE PROVIDED PLASTIC HANDLES (INSERTERS, EXTRACTORS).

NO REPAIRS IN THE FIELD ARE ALLOWED. THE EQUIPMENT SYSTEM III MUST BE RETURNED TO THE MANUFACTURER FOR REPAIRS.

Section 1 - Introduction

Figure 1-1, SG-System III

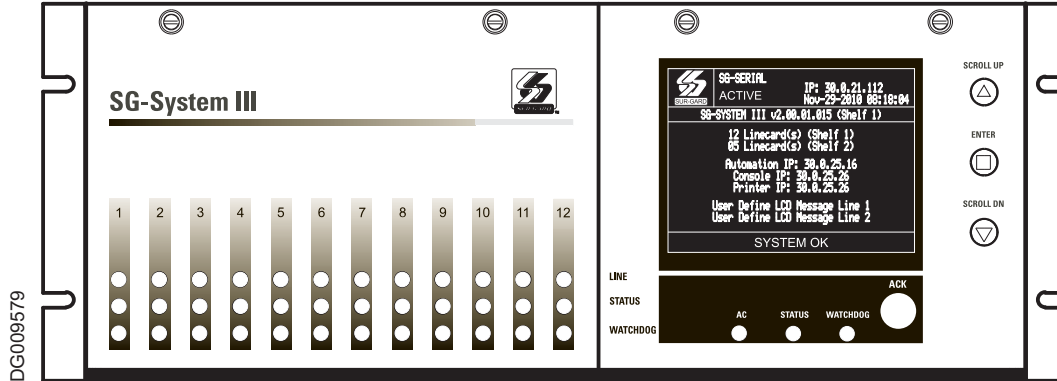

The SG-System III is a multi-platform digital telephone receiver intended for remote monitoring of commercial fire and burglary systems.

The SG-System III equipped with SG-DRL3/SG-DRL3-2L/SG-DRL3-IP can monitor up to 24/48 telephone lines, 24 IP communication line cards, or a combination of the two: receive and process alarm data in up to 64 pre-programmed formats (profiles) per line card. The SG-System III real time clock and calendar stamps all received alarm data which are then transmitted to a central station computer via TCP/IP or RS-232 port; transmitted directly to a printer using the parallel printer port; and viewed on the LCD of the front panel. System configuration and phone line profiles can be programmed using a PC with SG-System III Console Software or locally using the scroll buttons and LCD. Each rack can house up to 12 SG-DRL3, SG-DRL3-2L or SG-DRL3-IP.

1.1 System Overview

1.1.1 SG-DRL3/SG-DRL3-2L

- Patented Caller Identification (Call Display) capability
- Patent pending AHS (Automatic Handshake selection)
- Patented virtual configurations
- Non-volatile RAM on each SG-DRL3/SG-DRL3-2L line card for programming and event buffer
- Flash download for software upgrades for the SG-DRL3 line cards and the SG-CPM3
- DSP technology (patent pending)
- Up to 64 different options set (profiles per line card)
- Up to 8 different handshakes per profile
- Large, easy to read LCD (Liquid Crystal Display)
- All modules function individually to help ensure uninterrupted operation during hardware or software upgrades
- All cards are **Hot Swappable**. Printed circuit cards can be removed and replaced without removing power from the system or compromising the system performance
- 24 lines maximum per redundant receiver
- 512-event memory buffer on each individual line card.
- Real-time clock
- One parallel printer port, two serial RS-232 ports and 10/100BaseT connection per rack
- Operator Acknowledge
- Programmable serial ports configuration
- Continuous verification of the computer-receiver links with the 'heartbeat' function
- Fast transmission of multiple alarms to the computer and printer to ensure operator's quick response
- Telephone Line supervision
- Rack mount in standard 19 inch rack
For UL listed installations use MLR2-CL, MLR2-CM, IMRAK 1400 or other equivalent listed enclosure.

1.1.2 SG-DRL3-IP

- SG-DRL3-IP line card features include the following:
- Provides higher line security than conventional dial up panels with the polling feature.
 - Quicker transmission since dialing or handshaking is not required.

- The control panel is the originator of the signals and as such will be the one requesting the ACK from the central station.
- Network trouble detection is displayed on LCD/Printer and automation software.
- Disconnect trouble detection.
- Static IP for programming of the network protocols.
- Data network polling environment for replacement of an existing DVACS network. Meets the 90-second ULC requirement for this option.
- SIA event descriptors are used when transmitting information to the central station from the control panel through the PCLink connection.
- A security function communicates to the central station when a module is removed and replaced.
- The T-LINK accounts table and data encryption keys will be stored in the local database.

NOTES: The SG-DRL3-IP can only receive data from the following transmitters:
 TL150, TL250*, TL250DV, TL300*, GS3055*, GS3055-I, GS3055-ICF, GS3060*, TL26X*, GS206X*, TL26XGS, GS31XX
 * UL/ULC Listed, x = 0, 5.
 The SG-DRL3-IP Receiver Module is NOT compatible with the T-LINK TL100.

1.2 Approvals

1.2.1 Industry Approvals

- UL 1610 Central Station Burglar Alarm Units
- UL 864 Standard for Control Units and Accessories for Fire Alarm Systems
- CAN/ULC-S304-06 Signal Receiving Centre and Premises Burglar Alarm Control Units
- CAN/ULC-S559-04 Equipment for Fire Signal Receiving Centres and Systems
- EN60950-1:2006 Standard for Information Technology Equipment.
- AS/NZS 60950:2000 Information Technology Equipment - Safety
- CISPR22 Information Technology Equipment - Radio Disturbance Characteristics - Limits and Methods of Measurements
- EN50130-4 Immunity requirements for components of fire, intruder and social alarm systems

This equipment shall be installed in accordance with the requirements of NFPA72, NFPA70, UL827 and the authority having jurisdiction.

SG-System III with SG-DRL3-IP Line Card is ULC listed for active communication channel security level A1 - A4 when used in conjunction with T-Link TL250 and T-Link TL300, TL260, TL260GS, GS2060 Internet/Intranet and/or GSM-GPRS alarm communicators. For this type of application the supervision and encryption features have to be enabled.

For ULC Installations the equipment shall be installed in accordance with the requirements of ULC-S561 and ULC-S301 Standards and the authority having jurisdiction.

UL864 Programming Requirements

Table 1-1: UL864 Programming Requirements

NOTICE to Users, Installers, Authorities having Jurisdiction, and other involved parties				
This product incorporates field programmable software. In order for the product to comply with the requirements in the Standard for Control Units and Accessories for Fire Alarms Systems , UL 864, certain programming features or options must be limited to specific values or not used at all as indicated below.				
SG-CPM3				
Opt#	Program Option	Permitted in UL 864? (Y/N)	Possible Settings	Settings Permitted (UL 864)
12	Heartbeat Timer	Y	00-FF	Not allowed 00
13	Mute Buzzer	N	ON/OFF	OFF
16	PSU 1 Mask	N	ON/OFF	OFF
17	PSU 2 Mask	N	ON/OFF	OFF
18	DCA 1 Mask	N	ON/OFF	OFF
19	DCB 1 Mask	N	ON/OFF	OFF
1A	DCA 2 Mask	N	ON/OFF	OFF
1B	DCB 2 Mask	N	ON/OFF	OFF
1C	Reserved	N	ON/OFF	OFF
1D	Reserved	N	ON/OFF	OFF
1E	Fan 1 Mask	N	ON/OFF	OFF
1F	Fan 2 Mask	N	ON/OFF	OFF
20	Mask UPS 1 AC	N	ON/OFF	OFF
21	Mask UPS 1 Bat	N	ON/OFF	OFF
22	Mask UPS 2 AC	N	ON/OFF	OFF
23	Mask UPS 2 Bat	N	ON/OFF	OFF
24	Mask SG TCP 1	N	ON/OFF	OFF
25	Mask SG Serial 1	N	ON/OFF	OFF
26	Mask SG TCP 2	N	ON/OFF	OFF
27	Mask SG Serial 2	N	ON/OFF	OFF
28	Mask TCP Printer 1	N	ON/OFF	OFF
29	Mask Parallel 1	N	ON/OFF	OFF
2A	Mask SG Serial 1	N	ON/OFF	OFF
2B	Mask TCP Printer 2	N	ON/OFF	OFF
2C	Mask Parallel 2	N	ON/OFF	OFF
2D	Mask SG Serial 2	N	ON/OFF	OFF
SG-DRL3/SG-DRL3-2L				
Opt#	Program Option	Permitted in UL 864? (Y/N)	Possible Settings	Settings Permitted (UL 864)
04	2-Way Audio Activation Time	Y	00-FF	00
1C	BUSY OUT (For SG-DRL3 only)	Y	00-FF	00
042	BUSY OUT (For SG-DRL3-2L only)	Y	00-FF	00
2F	Online Time Out	Y	00-FF (00-255s)	00
7A	4 and 5 Digit Account Codes to Activate 2-Way Audio	Y	00-FF	00
7B	3-Digit Account Codes to Activate 2-Way Audio	Y	00-FF	00
7C	Alarm Codes to Activate 2-Way Audio	Y	00-FF	00
7D	Audio Zone Code	Y	00-FF	00
SG-DRL3-IP				
Opt#	Program Option	Permitted in UL 864? (Y/N)	Possible Settings	Settings Permitted (UL 864)
13	Transmitter Failure Debounce Time	N	OFF	OFF
15	Transmitter Restoral Debounce Time	N	OFF	OFF
19	Mask Transmitter Restoral	N	OFF	OFF
1A	Mask Transmitter Failure	N	OFF	OFF
1B	Mask Transmitter Swap	N	OFF	OFF
1C	Mask Transmitter Unencrypted	N	OFF	OFF
1D	Mask Invalid Report	N	OFF	OFF
1E	Mask Unknown Account	N	OFF	OFF
1F	Mask Supervised Acc Exceeded	N	OFF	OFF

Parallel Printers

For UL and ULC Listed applications the following UL/ULC Listed printer can be used with the SG-System III:

- Seiko DPU-414

Serial Printers

For UL and ULC Listed applications the following UL/ULC Listed printer can be used with the SG-System III:

- Seiko DPU-414

NOTE: Do NOT use printer cables that have only 1 common ground wire.

1.2.2 UL Manual Mode

For UL manual mode, each event will activate the internal buzzer to be acknowledged manually. Each event will also be sent automatically to the connected printer.

For Central Station applications, the signaling performance of each DACT (Digital Alarm Communication Transmitter) shall be manually tracked. Failure to receive a signal from a DACT over 24 hour period shall be handled as a trouble signal.

1.3 Description (Hardware)

Basic Configuration: The basic configuration consists of one 19" rack mounted chassis comprising the following:

- **SG-BP3X Backplane** provides interconnection of modules and communications interface
- **SG-CPM3 Module** contains the CPU that controls all communication to and from up to 24 line receiver modules, printers, including 2 serial ports and an Ethernet connection.
- **SG-PSU3 Power Supply Unit** provides power to all modules of the system.
- **SG-DRL3 Line Card:** Each SG-DRL3 line card monitors one telephone line. Stores on the card up to 64 profiles for data management including 8 different handshaking protocols. Each card has a 256-event buffer, for short term retention of signals.
- **SG-DC/DC3** provides 5 VDC power output required for the SG-DRL3 line cards. A slot exists for a second SG-DC/DC3 voltage converter. In the event of a failure, the redundant SG-DC/DC3 can be removed/replaced without powering down the unit.
- **SG-PSC3 (Power Supply Controller)** monitors the states of the power and fan for each SG-MLRF3.
- **SG-MLRF3:** The metal rack of the SG-System III that incorporates the LCD and SG-BP3X.
- **SG-DRL3-2L Line Card:** Each SG-DRL3-2L line card monitors up to two telephone lines. Stores on the card up to 64 profiles for data management including 8 different handshaking protocols. Each card has a 256-event buffer, for short term retention of signals.
- **SG-DRL3-IP Line Card:** Each SG-DRL3-IP line card supports up to 1536 IP transmitters and can supervise up to 512 transmitters. Each line card has a 512-event buffer, for short term retention of signals.

1.3.1 SG-BP3X Backplane

The SG-BP3X provides for interconnection of system modules and racks; and provides communication outputs as indicated in figure 1-6.

1.3.2 SG-DC/DC3 5V Power Converter

Each SG-DC/DC3 converts 15VDC input from the SG-PSU3 module and outputs the 5VDC required for all modules to function. A slot is provided for a second SG-DC/DC3 power supply to provide full redundancy for 5VDC power requirements. Power will remain ON if there are two SG-DC/DC3 in the rack. The SG-DC/DC3 is also **Hot Swappable** if a working redundant SG-DC/DC3 is in the same rack.

Figure 1-2

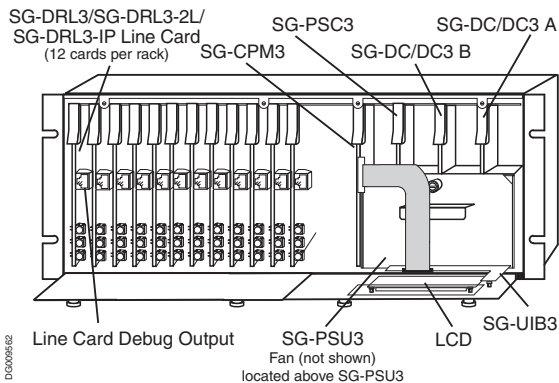

1.3.3 SG-PSU3 Power Supply Unit

The SG-PSU3 is the SG-System III power supply. The SG-System III requires a 120VAC/60Hz input power source. A power cord with a IEC connector is required. The model SG-System III CE requires a 240VAC, 50Hz input power source.

NOTE: For UL/IULC installations use only 120VAC/60Hz to power the SG-System III.

For UL installations use UL listed UPS Power Supply for protective signaling systems and/or listed burglar alarm power supply, as applicable.

The model SG-System III CE is not UL/IULC Listed.

Electrical Specifications:

SG-System III

- Input voltage range: 120 VAC
- Frequency: 60 Hz
- Input current: 2.5A max (RMS) @120 VAC

In 2-rack configurations a redundant SG-PSU3 can be inserted in the second shelf. In the event of a SG-PSU3 failure, the redundant SG-PSU3 automatically assumes operation. These modules are **Hot Swappable** (can be removed/replaced while the system is in operation) if a working redundant SG-PSU3 is installed.

1.3.4 SG-PSC3 Power Supply Controller

The SG-PSC3 performs two functions; it provides the high voltage required for backlighting to the LCD display. It also monitors the activity of the SG-PSU3, SG-DC/DC3 power supplies and the power supply fan, and reports their status to the SG-CPM3 module.

1.3.5 SG-CPM3 Central Processing Module

The SG-CPM3 Central Processing Module collects system information and directs line card information to the appropriate outputs. Along with its built-in scroll buttons and large LCD message screen, the SG-CPM3 features TCP/IP, parallel printer and two serial RS-232 ports for computer interface capability. The printer is supervised for loss of power, off-line, paper out and other trouble conditions. The communication link to the computer through the RS-232 and TCP/IP port can be monitored by the supervisory heartbeat test transmissions.

1.3.6 Line Cards

The SG-System III supports a maximum of 24 line cards. Each module is equipped with non-volatile memory to record events and corresponding telephone numbers. For each POTS card (SG-DRL3 and SG-DRL3-2L), calling source (Caller ID, ANI and calling name) capability is built-in and telephone numbers can be printed out, sent to automation and stored in memory. Events and information stored in memory may be printed at any time. Each line card type also features flash downloads through Ethernet for fast software upgrades. The SG-DRL3-2L may also perform flash updates over the front edge USB port connection.

The SG-DRL3/SG-DRL3-2L receives ANI (Automatic Number Identification) and/or DNIS (Dialed Number Identification Service) via the Telco connection. This information allows the Sur-Gard expert format identification system to change options on the fly for each received call. This eliminates dedicated line pool hardware. The DNIS information is used in a look-up table, which sets up virtual line pools to identify security formats and extend account numbers. Standard dialed number identification is supported up to 10 digits. Each dialed number would have formerly been a line pool on conventional line cards.

The SG-DRL3-IP (UDP) Receiver Module functions as a LAN or WAN server to many remote clients (the transmitters). The SG-DRL3-IP receiver module receives alarm events from the transmitter/panel (or from the transmitter when the transmitter is in standalone mode) and forwards them to the SG-CPM3 for subsequent output to the printer and automation outputs.

After a receiver module has been configured and installed, it will run on a predefined port and await communications from transmitters which have been configured to connect to that specific receiver. When communication has been established, the transmitter will enter its normal operating mode (waiting for panel polls, transmit heartbeat signals, alarm messages and DLS/SA download messages). The SG-DRL3-IP will log the connection and generate the appropriate connection event for forwarding to the SG-CPM3.

When an alarm message is generated, the transmitter will send the message in a UDP/IP/Ethernet frame and pass it along to the receiver (this communication can be optionally encrypted - reference transmitter documentation to determine if encryption is supported by the device). When an alarm message is received from the transmitter/panel, the receiver will strip off the UDP/IP/Ethernet frame and decrypt the message. It will then send an appropriate response (ACK or NAK) back to the transmitter/panel. The timing will follow the standard timing requirements of the panel. If the message was a valid alarm event, the event will be sent to the appropriate connected printer and automation devices.

The SG-DRL3-IP Receiver Module receives heartbeats from all network supervision enabled transmitters periodically. This allows the receiver to determine whether the transmitters are still online. The receiver maintains a table of all installed transmitters and monitors their status (presence/absence, installed software versions, MAC addresses for swap detection purposes, and other network statistics).

The SG-DRL3-IP Receiver Module can be programmed with various configuration parameters and options, including receiver IP address, receiver sub net mask, and default gateway address. Configuration parameters are password protected. The default password can be changed during initial installation for maximum security.

The SG-DRL3-IP Receiver Module is programmed with a globally unique MAC address during production. This MAC address is NOT re-programmable.

NOTE: Each SG-DRL3-IP Receiver Module can monitor up to a maximum of 1536 accounts of which 512 accounts can be supervised.

1.3.7 SG-BP3X Interface Module (optional - one required per rack)

This 19" Rack-mounted panel interfaces with the SG-System III Telco connector to provide 24 RJ-11 connectors for direct connection to telephone lines.

NOTES:

SG-DRL3: On the BPX3, the B ports are the channels used for 2-way audio or back-up telephone line.

SG-DRL3-2L: On the BPX3 the B ports are the channels used for channel 2 of the line card.

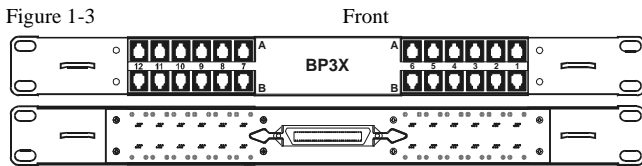
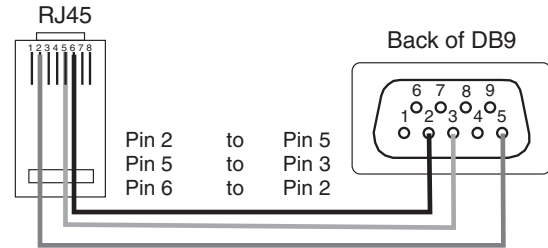

Figure 1-3

NOTE: Non-printable characters are replaced by a square on the print out. Ensure that the printer is configured for 80 columns (SG-System III only supports 80 columns).

- **Connections for Redundant SG-System III:** Refer to Figure 1-7 SG-System III Redundancy Wiring Diagram.
- **Line Card Debug Output:** Connect the RJ-45 end of the debug cable to the debug output jack. Connect the female DB-9 connector to the serial port of a computer (COM1 port - usually DB-9 male).

Figure 1-4 SG-CPM3 Debug Cable



- **SG-DRL3 Debug Output:** Connect the RJ-45 end of the debug cable to the debug output jack on the front of the line card. Connect the female DB-9 connector to the serial port of a computer (COM1 port - usually DB-9 male).

Figure 1-5 SG-DRL3 Debug Cable

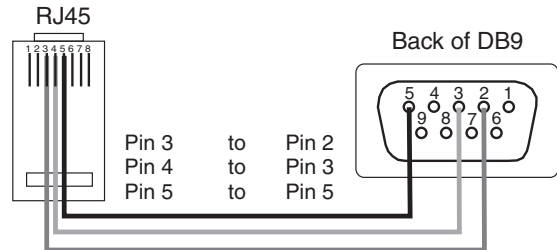

- **IEC Power Connector:** Provides local power line connection (cable is not supplied).

Figure 1-6, SG-System III Wiring Diagram

- * For Model System III CE:
- 240VAC /50Hz
- System III CE is not UL Listed

****CAUTION:** The Ethernet communication lines must be connected first to an approved (acceptable to the local authorities) type NID (Network Interface Device) before leaving the premises (e.g., UL installations, UL60950 Listed NID).

Connections for second backplane
See System III Supervised UPS Connection diagram for details

Note: For UL Installations:

- AC input is 120VAC / 60 Hz.
- Do not connect to a receptacle controlled by a switch.

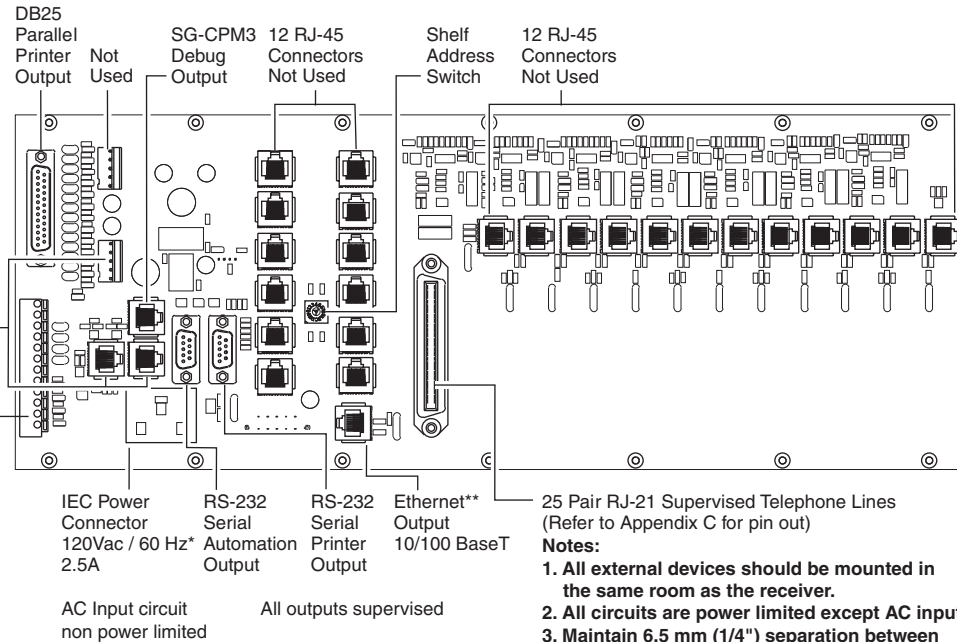

- Notes:**
1. All external devices should be mounted in the same room as the receiver.
 2. All circuits are power limited except AC input.
 3. Maintain 6.5 mm (1/4") separation between power limited and non-power limited circuits.

WARNING! To reduce the risk of electric shock the product is provided with a grounding type power supply IEC receptacle. Connect product using an appropriate IEC cable to a grounded receptacle.

- **RS-232 Serial Automation Output:** Provides serial connection to a local computer running automation software. A straight through serial cable must be used.
- **RS-232 Serial Printer Output:** Provides serial connection to a local computer or serial printer.
- **25 Pair Telco Connection:** Connects directly to the local PBX or to SG-BP3X (Refer to Appendix C for pinouts).
- **Ethernet Output 10/100 BaseT:** Traditional automation communication is provided via port 1025 on the Ethernet connection. This primary port is a Sur-Gard standard output and provides Sur-Gard

standard automation protocol output. All or a number of virtual receiver types can be mapped to the Sur-Gard output.

CAUTION: The Ethernet communication lines must be connected first to an approved (acceptable to the local authorities) type NID (Network Interface Device) before leaving the premises (e.g., UL installations, UL60950 Listed NID).

Figure 1-7, SG-System III Redundancy Wiring Diagram

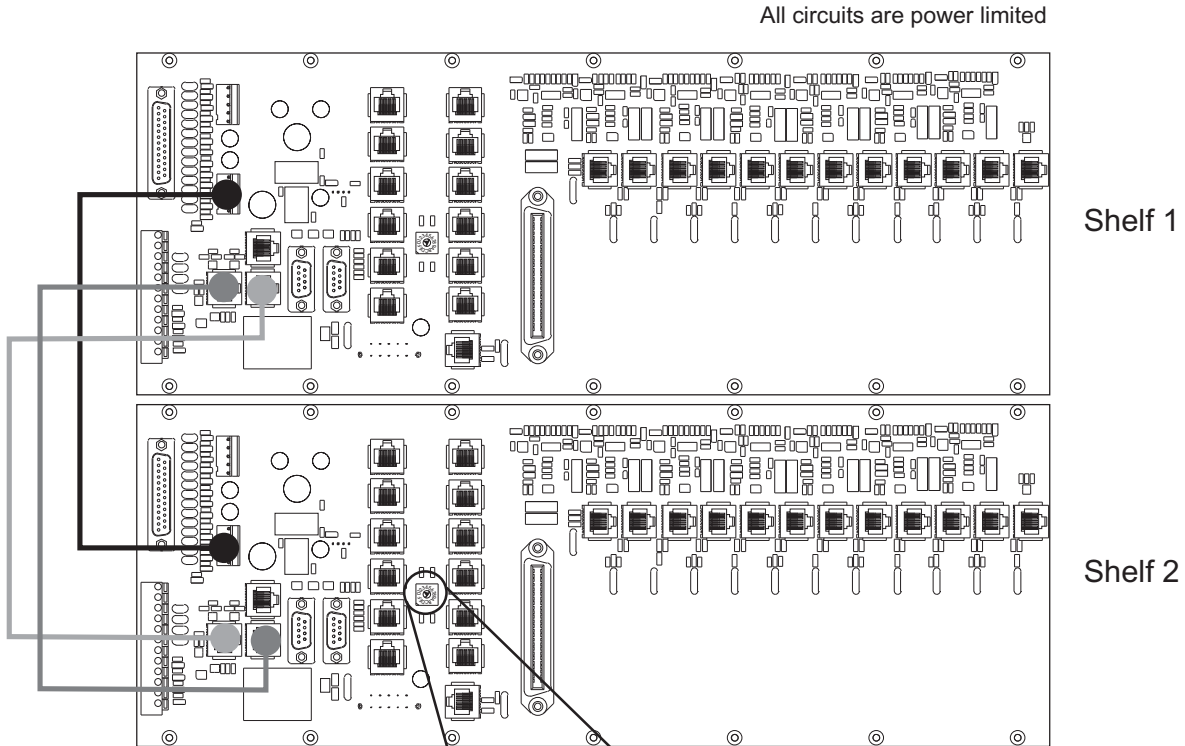

Use only the cables provided in the System III Interconnect Pack. Failure to do so may result in damage to the unit. Using the provided RJ-45 patch cables connect the Output of the primary System III (shelf address 1) to the Input of the redundant system III (shelf address 2). Connect the Output of the redundant System III to the Input of the primary System III.

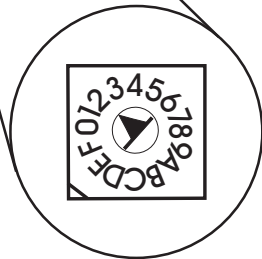

Use a small flat screw driver to turn the shelf address switch to 2 on the second redundant System III.

Figure 1-8, SG-System III UPS Supervision Connection Diagram

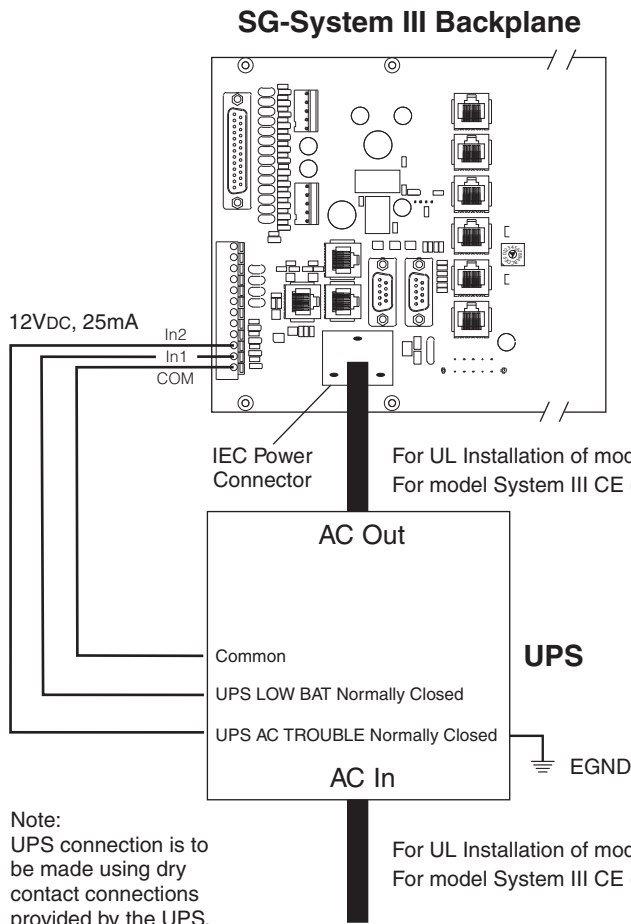

For UL/ULC installations use UL listed UPS (Uninterruptible Power Supply) power supply for protective-signaling systems and/or listed burglar alarm power supply, as applicable.

For ULC Installations, the equipment shall be rack mounted and energized by a permanently wired supply in accordance with C22.1, Canadian Electrical Code, Part 1, Safety Standard for Electrical Installations, section 32.

Connection to Uninterruptible Power Supply (UPS recommended) with minimum 24 Hr standby capability required.

For UL Installation of model SG-System III: UPS Output 120VAC/60Hz, 2.5A
 For model System III CE (not UL Listed): UPS Output 240VAC/50Hz

Note:
 UPS connection is to be made using dry contact connections provided by the UPS.

For UL Installation of model SG-System III: UPS Output 120VAC/60Hz, 2.5A
 For model System III CE (not UL Listed): UPS Output 240VAC/50Hz

WARNING:

To reduce the risk of electric shock the product is provided with a grounding type power supply IEC receptacle. Connect product using an appropriate IEC cable to a grounded receptacle.

Loading Capacities for Hunt Groups

System Loading at the Supervising Station	Number of Lines in Hunt Group				
	1	2	3	4	5-8
	With DACR lines processed in parallel				
Number of initiating circuits	NA	5,000	10,000	20,000	20,000
Number of DACTs	NA	500	1,500	3,000	3,000
	With DACR lines processed serially (put on hold, then answered one at a time)				
Number of initiating circuits	NA	3,000	5,000	6,000	6,000
Number of DACTs	NA	300	800	1,000	1,000

NA: Not allowed.

Figure 1-9, SG-System III Power Limited Circuit Separation from Non-Power Limited Circuit Diagram

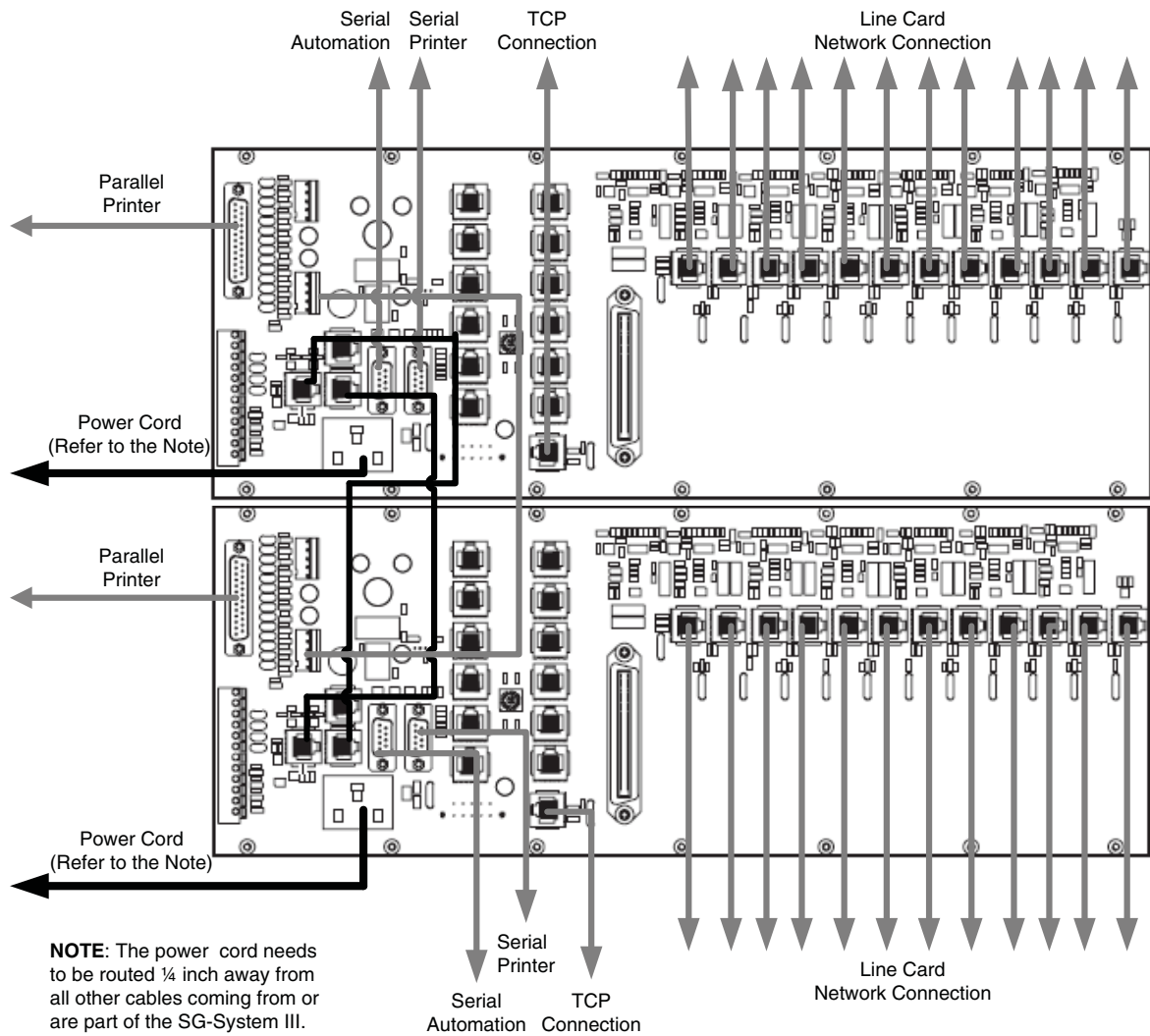

1.4 Receiver Setup and Operation

DSC recommends testing the receiver before actual installation. Becoming familiar with the connections and setup of the unit on the workbench will make final installation more straightforward.

The following items are required:

- IEC power supply cord
- One telephone line
- One or more dialer or digital control panel(s)

1. Unpack the components for the SG-System III.

NOTE: Carefully unpack the receiver and inspect for shipping damage. If there is any apparent damage, notify the carrier immediately.

2. Unscrew the front thumb screws and open the front plates.

NOTE: Before inserting the SG-CPM3, connect the ribbon cable from the SG-UIB3 board. Before inserting the SG-PSC3 connect the LCD backlight.

3. Insert all the cards in the rack, in their appropriate position (refer to figure 1-2). Connect the ribbon cable of the front panel to the SG-CPM3 before inserting it. Connect the backlight power connection to the SG-PSC3 then insert the SG-PSC3.
4. Insert the SG-PSU3 into the rack and fasten it properly.
5. Connect a telephone line to the proper line.
6. Connect the main power using a standard computer IEC cable (not supplied).
7. The LCD will power up and display internal troubles (printer, computer, telephone line fault). The SG-DRL3 that has the telephone line connected to it will have its red LED off. If the LED is always on make sure the telephone line is connected to the right port.

NOTE: Internal diagnostics may require more than one minute during the power up sequence.

8. Send a signal from a control panel to the receiver. The signal will be displayed on the LCD. Press the [ACK] button to silence the buzzer and clear the signal from the LCD.

1.5 Description (Operation)

1.5.1 Operation with Default Programming

Without any changes to the factory default programming, the receiver operates as indicated below:

- Answers incoming calls on the first ring
- Sends the following handshake order:

- 1 2300 Hz
- 2 1400 Hz
- 3 Dual-tone
- 4 SIA FSK
- 5 ITI, Modem IIE/IIIA2
- 6 Modem II

- Receives all communication formats, except for 3/2, 3/1 checksum, SKFSK, 4/2 extended, and 4/2 checksum (see Option 95).
- The above formats can be manually selected
- Signals can be displayed on the debug output computer as they are received. The signals are then sent to the printer and computer connected to serial port COM1 or to the 10/100BaseT connector. The default event codes described in the **SG-DRL3 Library Decoding and Event Codes Table** will be used with the Sur-Gard automation communication protocol to send signals to the computer, if connected.
- If a computer is not connected press the [ACK] button on the SG-CPM3 to silence the buzzer and to clear the alarm(s) from the LCD display.

1.5.2 Virtual Connectivity

Each receiver has one static IP address and a number of associated ports. Internal socket programming uses specific ports for expected tasks. The configuration management, done from the Console Software, is located on port 1024. The SG-System III Console software is provided for Microsoft Windows operating system (refer to the console documentation for compatibility listing), which provides a graphical style menu for configuration management. Additional features are available with the Console software including storage of virtual receiver setups and configuration wizards.

1.5.3 Status Addressing

Line card status is reported via physical addressing. Shelf and slot number are assigned automatically to each line card. All device status information is in Sur-Gard format. The reporting of status on this port, automation output and printer will relate to physical addressing.

1.5.4 Automation Input/Output (Port 1025)

Traditional automation communication is provided via port 1025 on the Ethernet connection. This primary port is a Sur-Gard standard output and provides Sur-Gard standard automation output.

1.5.5 Compatibility

Central station automation software packages such as:

- MAS
- DICE
- SIMS II
- GENESYS
- S.I.S.
- IBS
- MicroKey

support the SG-System III Sur-Gard interface. Refer to automation software specifications for compatibility.

NOTE: Automation connections are considered supplementary per UL864 Listing. Compatibility with the automation software in a system used at a central station is intended to be handled under a separate UL1981 software and/or site certification evaluation.

1.5.6 Automation Protocols

The SG-System III receiver sends a variety of protocols to report signals to the central station computer via a TCP/IP and/or RS-232 port. A complete list of protocols can be provided upon request.

1.5.7 Data Byte Protocol

The SG-System III receiver uses a default configuration of 9600 Baud rate, 1-start bit, 8-data bits, 0-parity bits and 1-stop bit structure, to transmit and receive signals on the RS-232 port. This protocol can be programmed on the receiver to enable different configurations.

1.5.8 Acknowledgment of the Signal

The SG-System III receiver requires an acknowledgment signal [ACK] (Hex 06) from the computer software within 4 seconds for each message sent. Failure to receive the [ACK] will result in 3 retransmissions of the signal before indicating a communication failure. During a communication failure the SG-System III receiver will cease transmitting except for the heartbeat. The same thing happens if the receiver receives a [NAK] (Hex 15). In case of communication failure with the computer, the SG-System III receiver can store up to 256 events per line card in the line card internal memory. Communication is resumed when the first acknowledgment is received on the heartbeat; all buffered information is then transmitted.

1.5.9 COM Responses

When the SG-CPM3 sends an event to the computer, it checks for 3 responses: ACK, NAK or Unknown/No Response. An ACK tells the SG-CPM3 the computer automation got the event successfully. A NAK tells the SG-CPM3 the computer automation received the message but didn't understand it. The line card will attempt to send the messages 25 times. If after 25 attempts it continually gets a NAK from the computer automation, the SG-DRL3 will generate an internal communication error. After 20 NAKs the SG-CPM3 will send an internal communication error event to the printer. Any other response from the computer automation, including no response will cause the SG-CPM3 to attempt to send the message again, up to 4 times. If after 4 attempts the SG-CPM3 gets no response or an unknown response, it will assume nothing is connected, generate an alarm and fall to the next active automation port or manual mode.

1.5.10 Automation Absent

When the computer is not responding to transmissions, the SG-CPM3 will generate a 'SG-Serialx fail' or 'SG-TCP/IPx Fail' trouble. When a trouble occurs, the SG-CPM3 will continue to attempt to send a heartbeat signal to the computer until it gets a response. The SG-System III receiver will make 4 attempts, then wait for the next heartbeat period before making another 4 attempts. The typical heartbeat interval is 30 seconds.

Supervisory Heartbeat Signal Protocol (1)	
00000	100000ssssssssss@ssss[DC4]
s	Receiver number (Real programmed number. Never virtual).
@	Space Character.
[DC4]	Supervisory Signal. Terminator, 14 Hex

This signal is used to supervise the communication between the receiver and computer automation. It is sent to the computer automation every 30 seconds and is programmable from the receiver. The computer automation should acknowledge this signal with an [ACK]. The SG-CPM3 can be programmed to send a heartbeat signal to the computer automation once every 01-99 seconds to test the connection between the SG-CPM3 and the computer automation (30 seconds is recommended). If a heartbeat fails to get a response from the computer automation, the SG-CPM3 will immediately transmit the heartbeat again, up to 4 attempts. The SG-System III, by default, will output the automation signals via TCP/IP. If TCP/IP fails it will switch to the Serial Automation output.

If the serial output fails, the SG-CPM3 will switch to manual mode, all signals will be displayed on the LCD and will require a manual acknowledgement. To re-establish connection with the TCP/IP a reset SG fallback command must be generated from the Console software. If the line card buffers are full, the line cards will stop answering calls.

1.5.11 SG-System III SIA Internal Status Output

0	0RRLLL[#0000]NYZZZZ]
RR	Protocol ID
LLL	Receiver number of the SG-CPM3
0000	Line card number, 000 signifies a SG-CPM3 Event.
NYZZZ	SG-System III account.
[DC4]	SIA Event Terminator, 14 Hex

Section 2 - SG-CPM3 Operating Modes

2.1 Contrast Adjust

Press the Up and Enter buttons together to increase the contrast or press Down and Enter together to decrease the contrast. This operation can be done at any time after the power up sequence.

2.2 Active Mode

In Active mode, the primary connection to the computer is via TCP/IP networking on the 10/100 BaseT Ethernet connection for the automation computer. If this fails, then the output will go via serial RS-232. A command can then be sent through the SG-System III Console software to revert back to TCP/IP when the connection is restored. The IP of the SG-CPM3 is displayed on the screen.

Figure 2-1, Active Mode



2.3 Manual Mode

For Manual mode, each event will activate the internal buzzer to be acknowledged manually. Each event will be sent automatically to the connected printer and displayed on the SG-CPM3 LCD. Messages longer than 80 characters will be displayed on two lines. Once the signal is acknowledged, it will be cleared from the screen.

Figure 2-2, Manual Mode

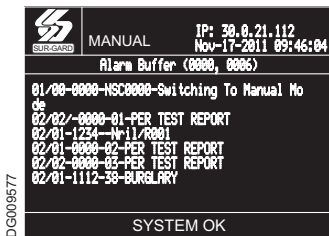

NOTE: The SG-CPM3 will display a maximum of 5000 events which have not been acknowledged.

2.4 Standby Mode

When two SG-CPM3s are present, one SG-CPM3 will be in Active or Manual mode, and the other SG-CPM3 will be in Standby. If the active SG-CPM3 fails, the standby unit will automatically take over the control of the system. The IP of the SG-CPM3 is displayed on the screen.

Figure 2-3, Standby Mode

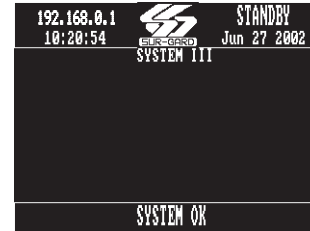

2.5 System Trouble and System Information

When a trouble is present on the SG-System III, the message 'SYSTEM TROUBLE' will be displayed at the bottom of the screen.

- To view which trouble is present, press the UP and DN buttons simultaneously. (All signal must be acknowledged before this is available.)
- If no troubles are present, pressing the UP and DN buttons will enter open the System Information menu. In this menu items such as Version information, Product ID, IP address can be viewed. If troubles occur once the user is in the Trouble menu, pressings the UP and DN buttons again will allow the user to access the System Information menu.
- To return to the main screen, press the UP and DN buttons simultaneously, or wait for timeout before this is available.

2.6 AHS Table Management

New and Modified AHS entries that are automatically generated by new incoming calls to line cards will be added to the backup CPM automatically. This operation will happen every 5 minutes. At this time all entries that are new/modified will be synchronized with the other CPM. If the two CPM's are not able to communicate to each other then the synchronization of the new entries will fail.

When the SG-Systems Console sets the AHS table to the CPM it will be written to flash once the set is complete.

Once the AHS table has reached capacity a log, AHS Database Full, is made. This message is only outputted once per day after the initial occurrence at midnight (24 hour time 0000). If table space is made (entries deleted) then no further logs will be made.

The AHS table size is 250000 entries. This may be increased to 500000 with the purchase of a license.

NOTE: The SG-CPM3ROHS is required in order to have the additional AHS entries.

Section 3 - Line Card Operating Modes

3.1 Standby Mode

3.1.1 SG-DRL3

After start-up the line card enters the Standby mode and monitors the telephone line and the SG-CPM3. Depending on the system's status, the following conditions will be displayed for each line card:

12 ● ● ●	LED	ON	OFF	FLASHING
	LINE (Red)	Line Fault	Line Normal	N/A
	STATUS (Yellow)	On-line	Off-line	*Error condition
	WATCHDOG (Blue)	Line Card not functional		Line Card functional

*The number of flashes on the yellow LED indicates the following errors:

Flashes	Error
1	CPM Absent
2	Line card clock not set
3	EBUS command to disable the line card was sent
4	Printer or computer buffer full.
5	Checksum failed when downloading Flash ROM files.

3.1.2 SG-DRL3-IP

After start-up the line card enters the Standby mode and monitors the network connection and the SG-CPM3. Depending on the system's status, the following conditions will be displayed for each line card:

12 ● ● ●	LED	ON	OFF	FLASHING
	LINE (Green)	Network Present	Network Absent	N/A
	STATUS (Yellow)	Trouble Condition(s)	Off-line	*Error condition
	WATCHDOG (Blue)	Line Card not functional		Line Card functional

*The number of flashes on the yellow LED indicates the following errors:

Flashes	Error
1	CPM Absent
2	Line Card Busy
3	Printer Buffer Full
4	Computer Buffer Full
5	Checksum Failed

3.1.3 SG-DRL3-2L

After start-up the line card enters the Standby mode and monitors the telephone line and the SG-CPM3. Depending on the system's

status, the following conditions will be displayed for each line card:

12 ● ● ●	LED	ON	OFF	FLASHING
	Channel 1 Line (Red) Status (Yellow)	Line Fault On-line	Normal Off-line	*Error condition
	Channel 2 Line (Red) Status (Yellow)	Line Fault On-line	Normal Off-line	*Error condition
	Channel 3 Line (Red) Status (Yellow)	Line Fault On-line	Normal Off-line	*Error condition
	WATCHDOG (Purple)	Line Card not functional		Line Card functional

NOTE: The SG-DRL3-2L has two channels. the Line LED will be used to indicate the status of channel 1. The Status LED will be used to indicate the status of channel 2 per table above.

*The number of flashes on the yellow LED indicates the following errors:

Flashes	Error
1	CPM Absent
2	Line card clock not set
3	EBUS command to disable the line card was sent
4	Printer or computer buffer full.
5	Checksum failed when downloading Flash ROM files.

3.2 Line Fault

The SG-DRL3/SG-DRL3-2L verifies the telephone line voltage. The 'Line Fault' LED (Red) will come ON when the voltage drops below 12VDC.

When the line condition returns to normal, the 'Line Fault' LED will be shut OFF.

NOTE: Additional line fault operation if Backup Line option is enabled. See Backup Line option (Option 0E) for explanation.

3.3 SG-CPM3 Error

If the line card cannot detect the SG-CPM3 polling, the line card will start buffering incoming calls. Up to 512 alarm messages for the printer and computer will be retained in the line card event buffer. When the event buffer is full, the line card will stop answering the calls and the status LED will begin flashing. When the SG-CPM3 Error condition is corrected, the alarm messages in the event buffer will be transmitted to the SG-CPM3 with the corresponding time/date the alarm has been received.

3.4 SG-DRL3/SG-DRL3-2L Data Reception

During data reception, the yellow STATUS LED will turn on. The line card decodes all information received and stores the information in its Event Buffer. When a valid signal is received, the line card sends a kiss-off signal and transmits the decoded alarm signal to the computer and to the printer through the SG-CPM3. The line card will send each message it receives to the printer for review by the system operator. Two messages may be sent to the printer to indicate reception problems: the 'Fault Data' (Invalid Report) and 'Fault Call' (Communication Fail).

3.4.1 Fault Data Message

When this problem is encountered, the following information is transmitted to the printer and the computer:

SG-DRL3/SG-DRL3-2L

Printer:

```
Jun 25 1998-11:18:07-SS/OO-SG-12-234-0000-INVALID
REPORT
```

Computer:

```
012234[#0000:NYNSSOO]
```

This output for account code '0000' indicates that data has been received, but is not valid (for example, there are unmatched rounds or incorrect parity).

Fault Data Message:

When this problem is encountered, the following information is transmitted to the printer and the computer:

Printer:

SG-12-234-AAAAAA-YN-*Invalid Report 192.158.8.34*

Computer:

012234[#AAAAAA;NYN*192.158.8.34*]

This output for account code 'AAAAAA' indicates that data has been received, but is not valid (e.g.,The packet is encrypted and the SG-DRL3-IP does not have the proper key) or the T-LINK transmitter packet was rejected (NAK) four times by the receiver. Please also refer to Option 45.

SG-DRL3-IP

Printer:

Jun 25 1998-11:18:07-SS/OO-SG-12-234-0000-COMMUNICA-TION FAIL

Computer:

012234[#0000;NYCSSOO]

This output indicates that a call was received, but no data was detected. The call may have been a wrong number, or the calling control panel was unable to connect with the receiver's handshakes.

Computer message NACKed 25 consecutive times.

Printer message: Internal Comm. Error

Computer signal: RLLLL[#0000;NRTSSOO]

3.4.2 Ethernet Interface

The SG-DRL3-IP has an Ethernet interface which operates as a 10BaseT/100BaseT IEEE 802.3 compliant Ethernet port (half duplex mode). This port is accessible via a standard RJ45 connector. A LINK plus ACTIVITY LED is also present on the board for diagnostics and troubleshooting. The IP address of the SG-DRL3-IP is programmable. The Ethernet port is used for system connections, including the transmitter and console ports.

The Ethernet communication lines must be connected first to an approved (acceptable to the local authorities) type NID (Network Interface Device) before leaving the premises (e.g., UL installations, UL60950 Listed NID).

3.4.3 Supervised Receiver Database

The receiver has the capability of monitoring T-LINK transmitters that are set up as supervised units. The receiver will automatically keep track of new transmitters and indicate whenever a transmitter has been lost.

Section 4 - Programming/Operation

4.1 Introduction

The SG-System III can be programmed manually using the front panel; from a local computer using the Debug Output located on each line card behind the front panel; or remotely using the TCP/IP network and SG-System III Console software. The Debug output is intended as a testing and troubleshooting tool. Manual programming allows the user to program all of the SG-System III options for remote and local operation. Manual programming does not support the grouping of line cards into hunt groups or line pools.

4.2 Console Software

The Console software is intended to be the primary method of programming the system. Refer to the **SG-Systems Console Manual** for details.

4.3 Debug

The debug output is another method of accessing the line card's programmed options and diagnostics features. A debug cable is required to connect by serial communication from the line card to a standard PC running Windows 95 or higher software.

NOTE: Debug programming only affects options in profile "0".

ALL PROGRAMMING WITH THE DEBUG SETUP IS LOST WHEN THE SYSTEM IS POWERED DOWN OR WHEN LINE CARDS ARE REBOOTED OR REMOVED FROM THE RACK.

4.3.1 Debug Cable Connectivity

- Connect the RJ-45 end of the debug cable to the debug jack on the front of the line card.
- Connect the female DB-9 connector to the serial port of a computer.

4.3.2 Debug Software Setup

- Using Windows 95 or higher, point and click on the **Start** button.
- Select **Programs** ▶ **Accessories** ▶ **Communications** ▶ **HyperTerminal**. Once in the HyperTerminal window, point and click on the 'Hypertrm.exe' icon.
- A connection description window is displayed with a prompt on the 'Name' category. Type a name. Point and click on the 'OK' button.
- A phone number window is displayed. Choose the direct to COM port required for connection and point and click on 'OK'.

NOTE: The SG-Systems Console may also be used allowing for PC's that do not have access to HyperTerminal to be able to program options and perform "logger functions". Refer to the SG-Systems console manual for setup instructions.

Figure 4-1



- The COMx properties windows are displayed.. The configuration should be:

SG-DRL3 - bits per second	19200
SG-DRL3-2L - bits per second	57600
SG-DRL3-IP - bits per second	19200
Data bits:	8
Parity:	None
Stop bits:	1
Flow control:	None

Figure 4-2

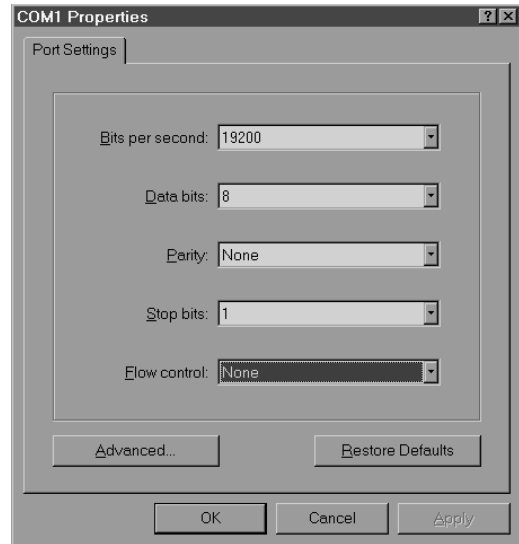

- Click on the 'OK' button after setting the configuration.
- The HyperTerminal window is displayed. Press any key. The debug menu is displayed.

4.4 Manual Programming

The user interface consists of 3 buttons: the Scroll Up button, the Scroll Down button, and the Enter button. These buttons are used to access the programming of the line cards and the SG-CPM3, and to view alarm and trouble messages in manual mode. They are located on the right side of the screen.

Figure 4-3



The Configuration mode allows programming of the various features and options available on the SG-System III. To enter the Configuration mode, press the [Enter] button.

Enter the Master Access Code using the buttons; the default Master Access Code is "CAFE".

When the access code is entered, the screen will display the Configuration Menu.

CPM Options allow the user to customize the operation of the system TCP/IP addressing, Passwords, COM settings and other system functions. Refer to the description of all CPM options and their default settings.

4.4.1 System Functions

- **Reset the SG-CPM3**
Restarts the SG-CPM3. This is required to make the changes to some options effective. For example, the IP address.
- **Date and Time**
Sets the date and time of the SG-System III. This can also be done from the Console software.

Visual Indicator Test

When selected, the SG-CPM will activate all front user interface enunciators and buzzers for 5 seconds. All LEDs will activate and all pixels on the LCD will activate (display turns white) for this duration. Any outputs set for Buzzer Follow or Trouble Output must also activate during this test.

The Visual Indicator test will also be sent to line cards if the CPM is in either Manual or Active modes.

Advanced Programming allows the user to customize line card profiles.

NOTE: Visual Indicator test should not be performed while other functions are active (such as line test/ASH Flash).

4.5 SG-CPM3 Options

NOTES: The following defaults are for the Primary SG-CPM3.

A Secondary SG-CPM3 will have the following MASK set to ON [1C, 1D, 20, 21, 22, 23, 25, and 27] at default, the remainder will be set to OFF. This is to reflect a full redundant system.

All references to OFF = option value of 00, and ON = option value of 01.

Option [01]: IP Address - Default [10.0.7.100]

This section is the IP of the SG-System III. The IP Address will be entered as a dotted decimal number. Example: 192.168.002.045. Each segment of the IP address shall have a valid range from 000 to 255. The IP address shall be entered in one menu in the programming menu even if multiple sections (octets) are used to generate the completed IP address.

NOTE: For changes to this program option a reset of the unit is required before the new parameters are used.

Option [02]: Subnet Mask Address - Default [255.255.0.0]

This section is the IP of the SG-System III. The Subnet Address will be entered as a dotted decimal number. Example: 255.255.000.000. Each segment of the IP address shall have a valid range from 000 to 255. The subnet address shall be entered in one menu in the programming menu even if multiple sections are used to generate the completed IP address.

NOTE: For changes to this program option a reset of the unit is required before the new parameters are used.

Option [03]: Gateway Address - Default [0.0.0.0]

This section is the Gateway of the SG-System III. The Gateway Address will be entered as a dotted decimal number. Example: 192.168.002.001. Each segment of the Gateway IP address shall have a valid range from 000 to 254. The subnet address shall be entered in one menu in the programming menu even if multiple sections are used to generate the completed IP address. The gateway is used in the event that the data being sent is not on the same network as the SG-System III. The data will need to be sent through a router device. This is the address of the router.

NOTE: For changes to this program option a reset of the unit is required before the new parameters are used.

Option [04]: Auto Update Time & Date - Default [0]

This option allows the automation to update the SG-System III time via the TCP/IP port. When enabled, should the SG-System III fail to get the time & date within 24 hours period (started after the last update is received or reset), it will generate a status message to the printer and automation, following the internal trouble protocol. The Trouble status on the SG-System III will not be affected. The Receiver Console time update function must be disabled when using this feature or there is a possibility that the System will not remain synchronized with the automation PC.

Printer message: "Time&Date Update Fail"
Automation message: 0RRLLL[#0000;NRU0000]

NOTE: The IP address and gateway must be on the same Subnet in order to change one or the other.

Option [05]: Contrast Adjust - Default [80]

Allows the contrast of the message display screen to be adjusted. The contrast can also be adjusted from any screen by holding the UP and ENTER buttons simultaneously to increase the level, or by holding the ENTER and DOWN buttons simultaneously to decrease the level.

Option [06]: Password Menu - Default [CAFE]

Allows the SG-System III users and passwords to be erased or changed. Sixteen users with 4-digit passwords are available for use on the SG-System III. User 0 is the Master user, and users 1 through F may be assigned to individual operators. The Master user will provide access to all menus, while the operators will have access to the SG-System III settings as a view only (except passwords), other than to set the time and date.

This is to meet ULC-S559 Standard applicable to Fire Monitoring Equipment. All users are able to ACK alarm messages and view the Trouble menu.

To erase a user, program the password for that user to 'FFFF'.

NOTE: User "0" cannot be erased.

Option [07]: COM1 Baud Rate - Default [9600]

Determines the baud rate at which the SG-System III will communicate to the automation software via serial port 1. Valid selections are: 1200, 2400, 4800, 9600, 19200, 38400, 57600.

NOTE: For changes to this program option a reset of the unit is required before the new parameters are used.

Option [08]: COM1 Data Bits - Default [8]

Determines the number of data bits used to communicate to the Automation Software connected on serial port 1. Choose a number from 7 or 8 to indicate 7, or 8 data bits.

Option [09]: COM1 Parity - Default [0]

Determines the parity of serial port 1.

Numeric Setting	Display	Description
0	None	no parity (default)
1	Odd	odd parity
2	Even	even parity

NOTE: The number of stop bits can not be changed and will always be 2.

NOTE: For changes to this program option a reset of the unit is required before the new parameters are used.

Option [0A]: Serial Printer Format - Default [0]

The Serial printer is Com 2 on the receiver. Setting option [0A] to "01" (this will display as CTS in programming mode), will require the CTS to be set high and print to both HyperTerminal and physical serial printer. By setting option [0A] to "02" (this will display as DCD in programming mode), DCD will need to be set high. This option affects how the COM2 Serial Port is supervised.

To disable the option set to [0].

To enable the printer messages to be outputted to a serial printer and a computer/HyperTerminal via the COM2, set to [1]. (This condition is for devices that set CTS pin HIGH.)

To enable the printer messages to be outputted to a serial printer and a computer/Hyper Terminal via the COM2, set to [2].

(This condition is for devices that set the DCD pin HIGH.)

NOTE: For changes to this program option a reset of the unit is required before the new parameters are used.

Option [0B]: Serial Baud Rate - Default [3] 9600

Determines the baud rate at which the SG-System III will communicate to the Automation Software connected on serial port 2.

Valid entries are: 1200, 2400 4800 9600 19200 38400, 57600.

Option [0C]: Serial Data Bits - Default [8]

Determines the number of data bits used to communicate to the Automation Software connected on serial port 2. Choose a number from 7 or 8 to indicate 7 or 8 data bits.

NOTE: For changes to this program option a reset of the unit is required before the new parameters are used.

Option [0D]: Serial Parity - Default [0]

Determines the parity of serial port 2.

Numeric Setting	Display	Description
0	None	no parity (default)
1	Odd	odd parity
2	Even	even parity

NOTE: The number of stop bits can not be changed and will always be 2.

NOTE: For changes to this program option a reset of the unit is required before the new parameters are used.

Option [0E]: AHS Operation Options - Default [24] (disabled)

This option is used to program the time at which the AHS table will be saved to flash. Valid entries for this section are from 00 (12 AM) to 23 (11 PM) - and 24 (disabled).

Primary and Secondary SG-CPM3 must have this option programmed with the same value.

New and Modified AHS entries that are automatically generated by new incoming calls to line cards will be added to the backup CPM automatically via port 1030. This operation will happen every 5 minutes. At this time all entries that are new/modified will be synchronized with the other CPM. If the two CPM's are not able to communicate to each other then the synchronization of the new entries will fail.

A text message shall be outputted to the printer when AHS synchronization starts, stops, or fails.

A text message shall be outputted to the printer when AHS flash write starts, stops, or fails.

Option [0F]: B32 Headers - Default [00]

Compatible with MAS B32 Automation Software through TCP/IP. To enable, change to [01].

B32 Headers apply only to TCP/IP automation messages, not serial messages or printer messages.

When enabled, ALL outgoing and incoming automation messages will contain 4 extra bytes at the start of each packet.

These four bytes are:

00 00 LL LL

Where:

LL LL = the BCD value of the size of the entire packet.

i.e., If the original length was 1B HEX bytes to be sent, the packet would be:

00 00 00 31 <original packet>

And the ACK back to the receiver would:

00 00 00 05 06

NOTE: The ACK back to the CPM (Ex. "30 30-30 35 06" ASCII) will be at the end of the packet.

NOTE: For changes to this program option a reset of the unit is required before the new parameters are used.

Option [10]: Input RRRLL Digits - Default [5]

Indicates the number of expected digits in the computer message header from the line card. This must be the same as Option [02] of the POTS line cards and option [11] of the IP line cards.

Option [11]: Output RRRLL Digits - Default [5]

Indicates the number of digits the receiver will send in the header to the automation output. This should be left as 5 unless the automation software does not support the SG-System III output protocol. This will affect both System style message and Channel style messages.

Option [12]: Heartbeat Timer - Default [30]

Determines at what time interval, in seconds, the heartbeat transmission will be sent to Serial Automation and TCP/IP port 1025. The heartbeat transmission is used to ensure that communications through Serial and TCP/IP are functioning normally when there is no traffic from the receiver. Any traffic from the receiver will reset the timer for the heartbeat. Therefore the heartbeat will only be sent if there is no signal sent during this option's value. Enter a decimal number from 01 through 99 to determine the time interval between heartbeat transmissions. Enter the value 00 to disable heartbeat transmission.

NOTE: When 00 is used heartbeats will not be sent to automation software - this will result in the connection to the automation software being unmonitored.

For UL Listed products, the permitted setting is 00.

Option [13]: Mute Buzzer - Default [OFF]

A tone will sound when the system receives an alarm and is unable to forward the alarm message to automation (COM1 or TCP/IP). The tone may be silenced with this option. If enabled, the buzzer will not sound when an alarm is received and cannot be forwarded to an automation output.

For UL Listed products, the permitted setting is OFF.

Option [14]: Receiver Number - Default [01]

The receiver number is used to identify the receiver when communicating to the TCP/IP Automation, COM1 and the printer. To change the receiver number, enter a new receiver number using the hexadecimal numbers "01" to "FE". This will be for all traffic unless overridden by other options.

Option [15]: Printer Test - Default [01]

When this option is enabled, a test signal will be sent to all active printer(s) at 05:00 and 17:00 hrs. This option is set to "0" (Off) by default.

Printer message:

26 Nov 2003 16:41:25 - 26 Nov 2003-16:41:25-00/00-SG -01-000-0000--Printer Test Message

Option [16]: Mask PSU 1 - Default [00]

Some installations may not have the full SG-System III configuration. This mask option is used to enable or disable the supervision of the Power Supply Unit for shelf 1. To not report the trouble, turn the appropriate option ON.

NOTE: PSU 1 is the SG-PSU3 installed in shelf 1

For UL Listed products, the permitted setting is OFF.

Option [17]: Mask PSU 2 - Default [01]

Some installations may not have the full SG-System III configuration. This mask option is used to enable or disable the supervision of the Power Supply Unit for shelf 2. To not report the trouble, turn the appropriate option ON.

NOTE: PSU 2 is the SG-PSU3 installed in shelf 2

For UL Listed products, the permitted setting is OFF.

Option [18]: Mask DCA 1 - Default [00]

Some installations may not have the full SG-System III configuration. This mask option is used to enable or disable the supervision of the right hand SG-DC/DC3 for shelf 1. To not report the trouble, turn the appropriate option ON.

NOTE: DCA 1 is the SG-DC/DC3 installed in shelf 1.

For UL Listed products, the permitted setting is OFF.

Option [19]: Mask DB 1 - Default [01]

Some installations may not have the full SG-System III configuration. This mask option is used to enable or disable the supervision of the left SG-DC/DC3 for shelf 1. To not report the trouble, turn the appropriate option ON.

NOTE: DCB 1 is the SG-DC/DC3 installed in shelf 1.

For UL Listed products, the permitted setting is OFF.

Option [1A]: Mask DCA 2 - Default [00]

Some installations may not have the full SG-System III configuration. This mask option is used to enable or disable the supervision of the right SG-DC/DC3 for shelf 2. To not report the trouble, turn the appropriate option ON.

NOTE: DCA 2 is the SG-DC/DC3 installed in shelf 2.

For UL Listed products, the permitted setting is OFF.

Option [1B]: Mask DB 2 - Default [01]

Some installations may not have the full SG-System III configuration. This mask option is used to enable or disable the supervision of the left SG-DC/DC3 for shelf 2. To not report the trouble, turn the appropriate option ON.

NOTE: DCB 2 is the SG-DC/DC3 installed in shelf 2.

For UL Listed products, the permitted setting is OFF.

Option [1C]: Reserved

For UL Listed products, the permitted setting is OFF.

Option [1D]: Reserved

For UL Listed products, the permitted setting is OFF.

Option [1E]: Mask Fan 1 Fail - Default [00]

Some installations may not have the full SG-System III configuration. This mask option is used to enable or disable the supervision Fan trouble for shelf 1. To not report the trouble, turn the appropriate option ON.

For UL Listed products, the permitted setting is OFF.

Option [1F]: Mask Fan 2 Fail - Default [01]

Some installations may not have the full SG-System III configuration. This mask option is used to enable or disable the supervision Fan trouble for shelf 2. To not report the trouble, turn the appropriate option ON.

For UL Listed products, the permitted setting is OFF.

Option [20]: Mask UPS AC 1 - Default [01]

UPS AC trouble mask for shelf 1. If set, UPS AC trouble conditions are not reported.

OFF: Condition reported

ON: Condition not reported (masked)

- Option [21]: Mask UPS BAT 1 - Default [01]**
 UPS Battery trouble mask for shelf 1. If set, UPS Battery trouble conditions are not reported.
 OFF: Condition reported
 ON: Condition not reported (masked)
For UL Listed products, the permitted setting is OFF.
- Option [22]: Mask UPS AC 2 - Default [01]**
 UPS AC trouble mask for shelf 2. If set, UPS AC trouble conditions are not reported.
 OFF: Condition reported
 ON: Condition not reported (masked)
For UL Listed products, the permitted setting is OFF.
- Option [23]: Mask UPS BAT 2 - Default [01]**
 UPS Battery trouble mask for shelf 2. If set, UPS Battery trouble conditions are not reported.
 OFF: Condition reported
 ON: Condition not reported (masked)
For UL Listed products, the permitted setting is OFF.
- Option [24]: Mask SG TCP 1 - Default [00]**
 SG TCP trouble mask for shelf 1. If set, SG TCP trouble conditions are not reported.
 OFF: Condition reported
 ON: Condition not reported (masked)
For UL Listed products, the permitted setting is OFF.
- Option [25]: Mask SG Serial 1 - Default [00]**
 SG Serial Automation trouble mask for shelf 1. If set, SG Serial automation trouble conditions are not reported.
 OFF: Condition reported
 ON: Condition not reported (masked)
For UL Listed products, the permitted setting is OFF.
- Option [26]: Mask SG TCP 2 - Default [00]**
 SG TCP trouble mask for shelf 2. If set, SG TCP trouble conditions are not reported.
 OFF: Condition reported
 ON: Condition not reported (masked)
For UL Listed products, the permitted setting is OFF.
- Option [27]: Mask SG Serial 2 - Default [01]**
 SG Serial Automation trouble mask for shelf 2. If set SG Serial automation trouble conditions are not reported.
 OFF: Condition reported
 ON: Condition not reported (masked)
For UL Listed products, the permitted setting is OFF.
- Option [28]: Mask TCP Printer 1 - Default [00]**
 SG TCP Printer trouble mask for shelf 1. If set, SG TCP Printer shelf trouble conditions are not reported.
 OFF: Condition reported
 ON: Condition not reported (masked)
For UL Listed products, the permitted setting is OFF.
- Option [29]: Mask Parallel Printer 1 - Default [00]**
 SG Parallel Printer trouble mask for shelf 1. If set, SG Parallel Printer shelf trouble conditions are not reported.
 OFF Condition reported
 ON Condition not reported (masked)
For UL Listed products, the permitted setting is OFF.
- Option [2A]: Mask Serial Printer 1 - Default [00]**
 SG Serial printer trouble mask for shelf 1. If set, SG Serial Printer trouble conditions are not reported.
 OFF: Condition reported
 ON: Condition not reported (masked)
For UL Listed products, the permitted setting is OFF.
- Option [2B]: Mask TCP Printer 2 - Default [01]**
 SG TCP Printer trouble mask for shelf 2. If set, SG TCP Printer shelf trouble conditions are not reported.
 OFF: Condition reported
 ON: Condition not reported (masked)
For UL Listed products, the permitted setting is OFF.

- Option [2C]: Mask Parallel Printer 2 - Default [01]**
 SG Parallel Printer trouble mask for shelf 2. If set, SG Parallel Printer shelf trouble conditions are not reported.
 OFF: Condition reported
 ON: Condition not reported (masked)
For UL Listed products, the permitted setting is OFF.
- Option [2D]: Mask Serial Printer 2 - Default [01]**
 SG Parallel Printer trouble mask for shelf 2. If set, SG Serial Printer trouble conditions are not reported.
 OFF: Condition reported
 ON: Condition not reported (masked)
For UL Listed products, the permitted setting is OFF.

- Option [2E]: Number of Line Cards- Default [CC] lines**
 This option is used to set the number of line cards polled by the SG-CPM3. This option is nibble controlled, upper nibble for shelf 2 and lower nibble for shelf 1. Valid entries are from 1 to C (Shelf 1 CPM) and 0 to C (Shelf 2 CPM) to indicate how many line cards are to be polled by the CPM. The number of line cards being polled must be programmed the same for each CPM.
 Line cards must be installed in order occupying each slot sequentially starting from slot 1 of shelf 1 through to slot 12, for each shelf. This option does not require that shelf 1 be fully populated with line cards prior to populating cards on the second shelf.
 Examples
 12 line cards on shelf 1 and 3 line cards on shelf 2
 -Both CPM would be programmed with 3C (shelf 1 – 12 line cards, Shelf 2 – 3 line cards)
 6 line cards on shelf 1 and 9 line cards on shelf 2
 -Both CPM would be programmed with 96 (shelf 1 – 6 line cards, Shelf 2 – 9 line cards)

- Option [2F]: Automation Mode - Default [01] (Fall Back)**
 The TCP/IP connection is the primary output of the automation computer alarms. It is estimated that sockets may appear and disappear regularly as processes are terminated and reconstituted. After 5 seconds of socket loss, a socket loss is declared and automation output is shifted to the other connection levels.
 This option is nibble controlled. The upper nibble controls the 6th configuration option (split shelf reporting), the lower nibble controls the automation mode

Upper Nibble (Hex)	Lower Nibble (Hex)	Description
0	0	Loop
0	1	Fallback
0	2	All
0	3	IP Fall Back
0	4	Automatic IP
1	0	Loop – split shelf reporting enabled
1	1	Fallback – split shelf reporting enabled
1	2	All – split shelf reporting enabled
1	3	Setting is not valid – return to default setting
1	4	Automatic IP – split shelf reporting enabled
2-F	5-F	Setting is not valid – return to default setting

NOTE: For changes to this program option a reset of the unit is required before the new parameters are used.

First Configuration: LOOP (0)

At start-up, the SG-System III will send to the TCP/IP until it fails, proceed to the RS232 until it fails, and proceed back to the TCP/IP until it fails, and so on. See Automation Mode Diagrams for flowcharts of each mode.

Second Configuration: FALL BACK (1)

If both outputs are present, the SG-System III will send to the TCP/IP until it fails, proceed to the RS232 until it fails, and will keep trying on the RS232 continuously, or until the reset fallback command is generated from the console, in which case it would go back to try the TCP/IP connection. See Automation Mode Diagrams for flowcharts of each mode.

Third Configuration: All Mode (2)

The CPM will always send to all connected outputs. If at least one output replies with an ACK, then the alarm is considered as transmitted regardless if the other output acknowledged it or not. This setting

is NOT recommended. See Automation Mode Diagrams for flowcharts of each mode.

Fourth Configuration: IP Fall Back Mode (3)

The CPM will always send to all connected outputs. If at least one output replies with an ACK, then the alarm is considered as transmitted regardless if the other output acknowledged it or not. This setting is NOT recommended. See Automation Mode Diagrams for flowcharts of each mode.

Fifth Configuration: AUTOMATIC IP SG-FALL BACK (4)

This mode is similar to Fall Back except that when the TCP/IP connection is restored the SG-System III will return to the System Interface to send events. This eliminates the need for the Reset SG Fallback from the SG-System III Console. See Automation Mode Diagrams for flowcharts of each mode.

Sixth Configuration: Split Shelf Reporting (5)

Split shelf reporting is a function that allows the receiver to have both shelves of the receiver output printer/automation messages independently.

All signals for each shelf will be outputted by the corresponding CPM. In the event that one of the CPM modules is removed or fails, the other will automatically take over processing of all automation and printer messages.

Option [30]: Printer Mode - Default [00] Loop

The printer outputs can be configured in a similar approach as the automation outputs except that only acceptable values are LOOP (01) or ALL (02). ALL is transmitting the printer message to all active ports. The first acknowledgment received will be used to process the next printer message.

NOTE: Order of sequence is TCP, Parallel and finally Serial. DSC does NOT recommend changing the default setting unless using more than one printer.

NOTE: The display for programming of the Printer Mode shall display the text label for the mode rather than the numeric value (example instead of 00 - display LOOP, instead of 02 - display ALL).

NOTE: For changes to this program option a reset of the unit is required before the new parameters are used.

Option [31]: ACK Wait - Default [40]

Determines the acknowledge wait time, in tenths of a second, to be used for automation outputs before the CPM will try again (if no response is received within this interval). This timer starts after the signal is sent to the automation.

Enter a decimal number from 40 to 99 for 4.0 seconds to 9.9 seconds.

NOTE: For changes to this program option a reset of the unit is required before the new parameters are used.

Option [32]: Date Format - Default [0]

Selects the format used to represent date for printer output. Format [1] represents US format (display will read MM/DD/YY). Format [0] represents International format (display will read DD/MM/YY).

Option [33]: Protocol ID - Default [0]

When this option is programmed as '0' the CPM will output its internal messages in the following format:

0RRLLL[#AAAA]Nxyy

When this option is programmed as 'S' the SG-System III will output its internal messages in the following format:

SRLLL[#AAAA]Nxyy

S,0 (zero): protocol number

RR: Receiver number

LLL: Line number

AAAA: Account code, always 0000

Nxyy: SIA event

Option [34]: Time Correct - Default [000]

The SG-System III will synchronize its time with the SG-System III console application PC. However in some situations it may be desirable to automatically correct the time of the SG-System III. The SG-System III will update its time once an hour. Valid values are -590 to +590; value represents time in tenths of a second (i.e. 243 means 24.3 seconds).

Option [35]: Reserved

Option [36]: Reserved

Option [37] and Option [38]: License Key

Option [37]: License key #1

Default 0000 0000 0000 0000 0000 0000 0000 0000

Option [38]: License key #2

Default 0000 0000 0000 0000 0000 0000 0000 0000

The default size of the AHS table is 250000 entries. With the purchase of a license the table size can be increased to 500000 entries. When purchasing the license key for the CPM the Product Id will be needed. The product ID can be found in the System Information menu or retrieved via the SG-Systems Console in the Status Menu for the CPM. Both CPM's will need to have a valid license entered in order to have 500000 AHS entries on each.

There are two sections for license key (Option [37]: License key #1, and Option [38]: License key #2) and both of them must be programmed correctly.

If the user has entered a license key in the product that is incorrect the receiver will output a printer only message "Invalid License Key" so that the user knows that the key entered is incorrect. If the key is 0's or correct no message will be generated. A key if all "0" is disabled.

Options [39] to [3D]: Reserved

Options [3E]: RBUS Speed

The system communication bus (RBUS) baud rate is programmable for two different settings 57600 and 520000. Each shelf of the CPM can have its own baud rate programming. This is done to accommodate line cards that have different setting capabilities. Each CPM has two RBUS connections, one for Shelf 1 and one for Shelf 2. This will allow one CPM to be able to poll/retrieve messages from any line card on the system regardless of the baud rate. When configuring the System all line cards on a shelf must have the same baud rate setting. Any cards that do not have the correct setting will not be seen by the CPM and signals received by that line card will not be outputted.

Values	Shelf-1 Bus Speed	Shelf-2 Bus Speed
00	57600	57600
01	520000	57600
02	57600	520000
03	520000	520000
04 - FF	57600	57600

Line Card compatible baud rates

Line Card Type Supported Baud Rates

SG-DRL3 57600

SG-DRL3-IP 57600

SG-DRL3-2L 57600 or 520000

Line cards capable of the higher bus speed will be able to determine their bus speed based on the shelf selector switch. This method does not apply to the CPM however.

Shelf selection Linecard RBUS Shelf to be reported

	Speed	(printer and automation)
1	57600	Shelf 1
2	57600	Shelf 2
3	Not valid - 57600	Shelf 1
4	Not valid - 57600	Shelf 1
5	520000	Shelf 1
6	520000	Shelf 2
7-16	Not valid - 57600	Shelf 1

Automation Mode Diagrams
 Flow Diagram for **Automation LOOP Mode (0)**

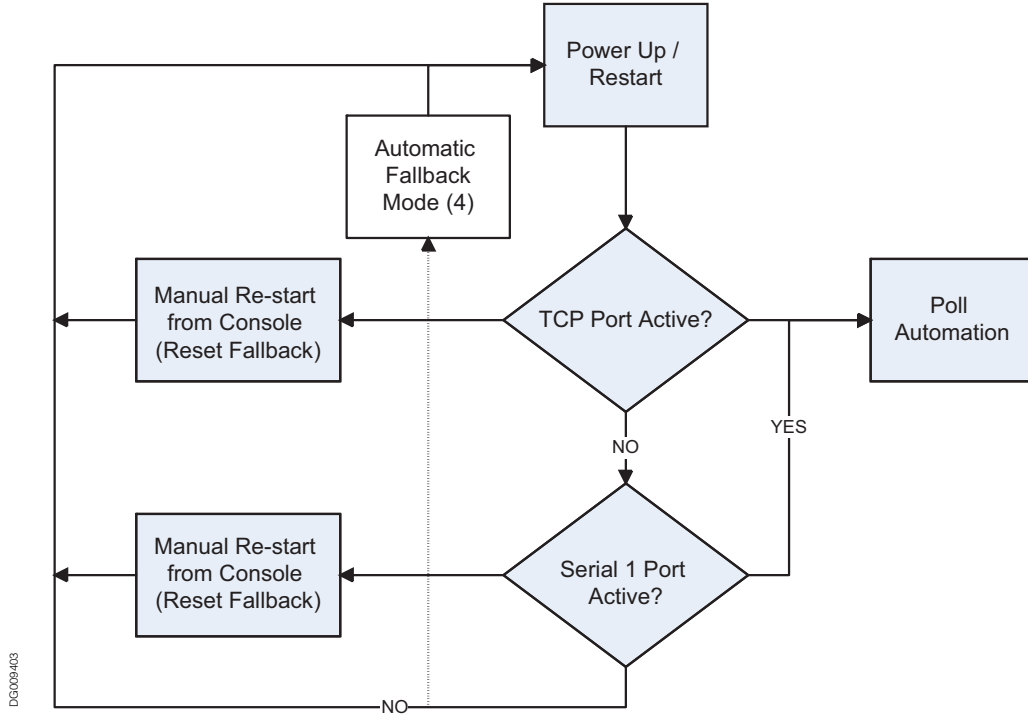

Flow Diagram for **Automation FALL BACK Mode (1)**

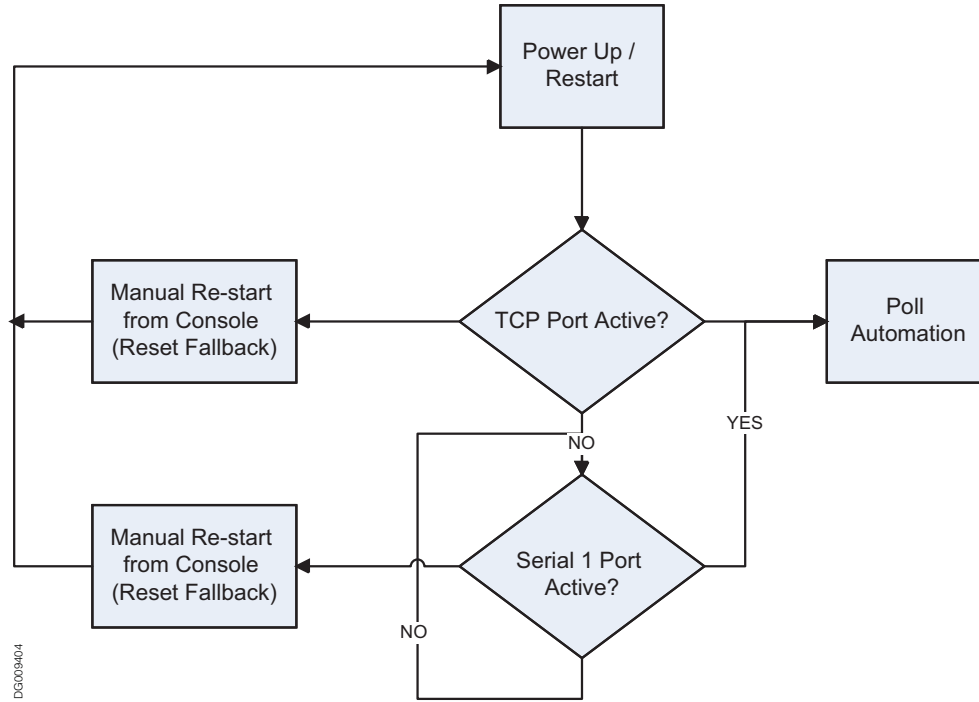

Flow Diagram for Automation ALL Mode (2)

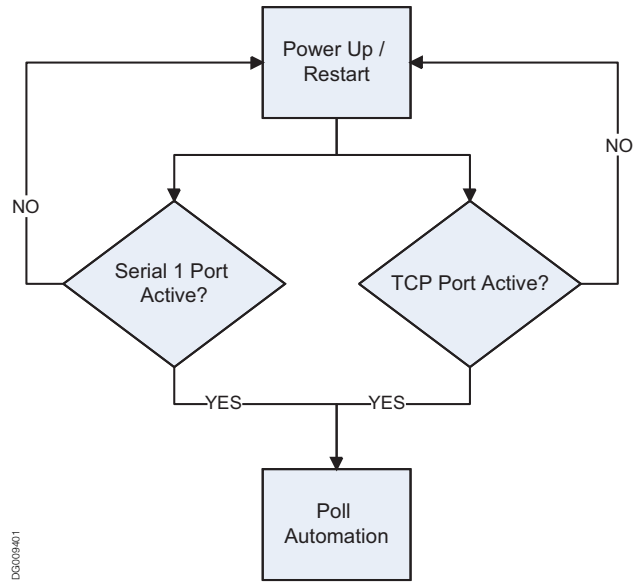

Flow Diagram for Automation IP FALL BACK Mode (3)

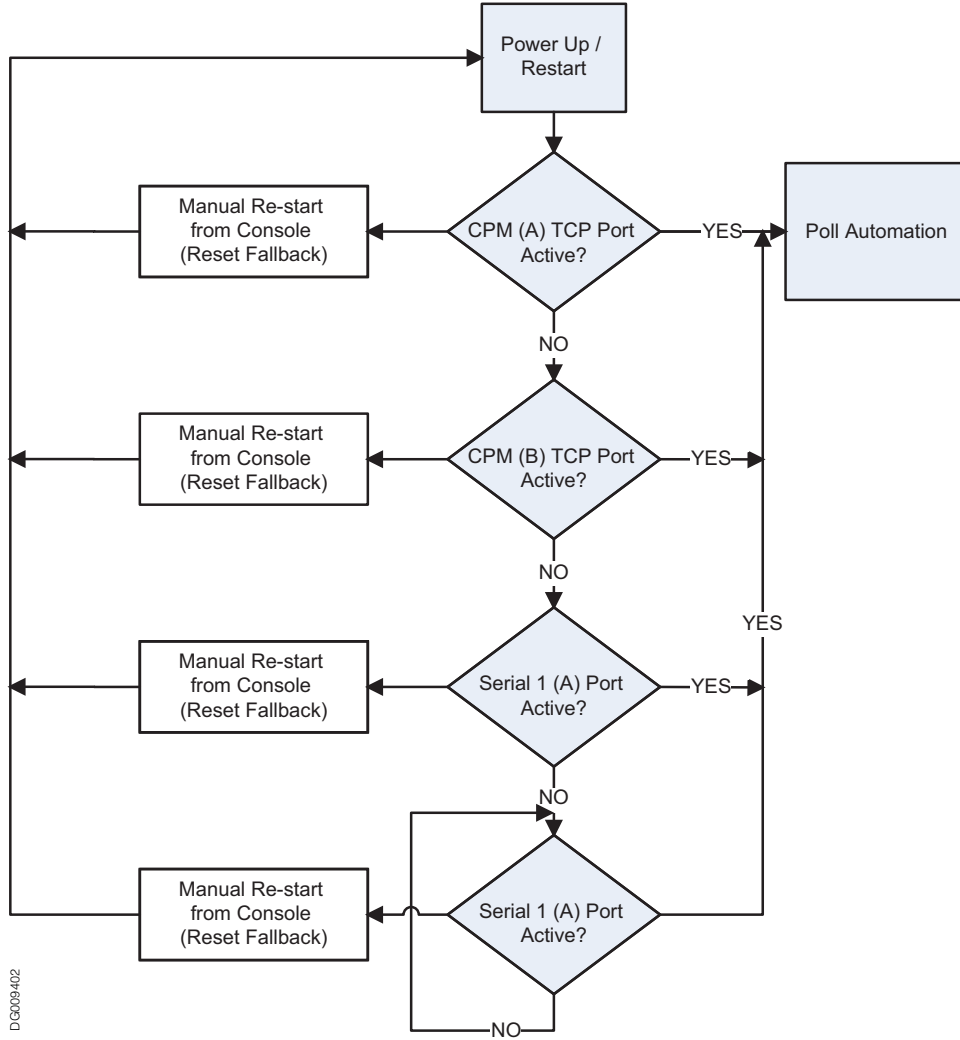

Section 5 - Advanced Programming

5.1 Profiles Introduction

The DRL3/DRL3-2L 'virtual receiver' will load unique 'profiles' in order to effectively communicate with control panels. A profile is a set of pre-programmed line card options unique for a particular DNIS number. The 'DNIS' will point to a particular profile, which will then be loaded into the line card before the first handshake is sent. It is essential that the correct option be programmed for a profile in order to correctly communicate with the control panel. Each 'virtual receiver' can have a maximum of 64 profiles. To change the options for a particular profile, the SG-System III Console software is provided. This software will allow the user/operator to edit the profiles.

NOTE: DNIS (Dialled Number Identification Service). This number represents the dialled number, or the number being called. **ANI: (Automatic Number Identification).** This number represents the source of a call and allows the system to determine the handshake protocol. **Caller ID: This number identifies the source of a call. For the purpose of this document, Caller ID and ANI will be referred to as Caller ID, but both can not be used at the same time. Contact your provider to determine which service is available.**

DNIS or Caller ID can be used for profile selection.

Line Cards Identification Number Handling:

Figure 5-1, Call Processing Flowchart

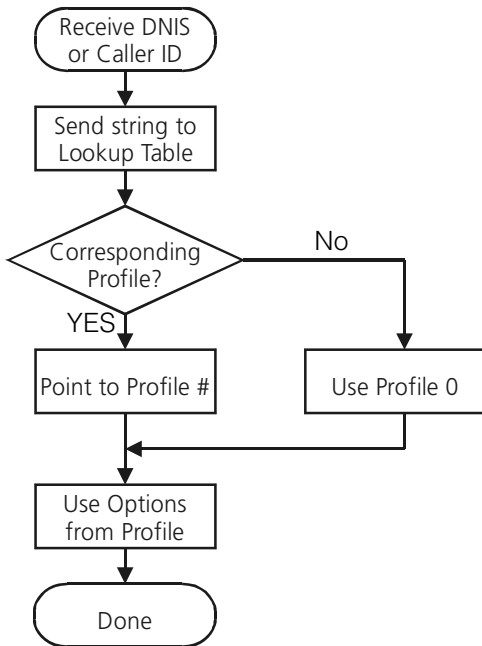

Each profile is made up of Static Options and Dynamic Options. The static options are the same for all profiles, but the dynamic options can be programmed specifically per hunt groups, panel type, etc.

By receiving the DNIS or Caller ID, the appropriate profile can be selected through a look-up table "stored" on the line card.

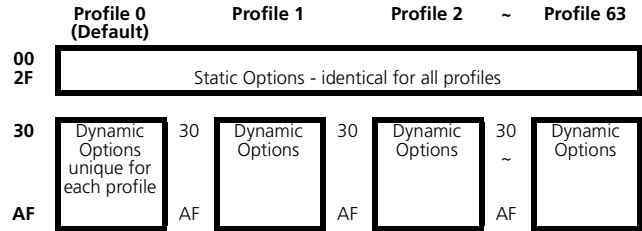

Profile 0 is the default. When no Caller ID or unknown DNIS is received, or when the received number does not point to a profile, the default will be used.

Profiles are used to reduce on-line time, and for specific customers or panel/format types, one can have a profile with certain handshakes sent first. Also, some formats require certain options, and this can be pre-defined as well.

Profiles allow for a more customized system. Rather than having a line card (or a receiver itself) devoted to certain customers, the SG-System III can "handle" any format at any time through the use of profiles. Each line card holds its own look-up table that can be shared through line pools, or shared within the entire receiver.

Two types of tables are available, but only one type can be chosen. The first type, which consists of 100 000 entries, is used strictly with DNIS of up to 5-digits.

Table type 1:

DNIS Received	Profile# to be used
00001	01
00002	03
00003	24
...	...
99999	45

The second type is used if ANI-Caller ID and/or DNIS are received, and can consist of up to 10,000 entries, with Caller ID or DNIS of up to 10 digits.

Table type 2:

Caller ID Number	Convert Data	Profile
05 603000	Not Used	0
05 603001	Not Used	1
05 603002	Not Used	2
05 603003	Not Used	3
DNIS Number	Convert Data	Profile
12345	54321	0
12346	54322	1
1234	54333	2

Each portion may contain 0-10000 entries with the total of all the entries not exceeding 10000.

The receiver will first check through the Caller ID section if a Caller ID number is received. If only a DNIS number is received, or Caller ID is received but the Caller ID was not found, it will check in the DNIS section.

On a standard receiver, the Automation output would look similar to the following:

```

1RRLLLsssssAAAAsYsZZ[DC4]
1DDDDsssssAAAAsYsZZ[DC4]
  
```

On the SG-System III, it will replace the RRLLLL, which is normally the receiver number and the line card number, by the DNIS received or the convert data found in the table.

This makes possible the duplication of accounts, as long as they are dialling different numbers.

The output will become:

Where DDDDD is the DNIS number. See Option 20 for more information on how to enable the combined table.

5.2 SG-DRL3-2L System Options

Option [000]-[005]: Reserved

Option [006]: Password Menu - Default [CAFE]

This password is only required if connecting directly to the line card for Code Uploads or performing other console operations directly to the line card (VIA USB).

The Password menu allows for a single password to be programmed. The password is 4 hex digits in length. All entries are valid 0000-FFFF hex.

NOTE: *This user cannot be erased.*

Option [007]-[03F]: Reserved

Option [040]: Channel Enable - Default [02]

This option is used to set the number of channels to be present on the line card. Valid entries are from 01 to 02.

01 - Only Channel one POTS is used - all reporting of status/trouble conditions for the second line will be masked and the channel will be busied out. Programming menu display will be C1.

02 - Both POTS channels are used. Programming menu display will be C1+C2.

All other values are not valid.

For channels that are disabled no information shall be displayed and no status troubles will be generated – any trouble conditions that exist when the channels are disabled will be restored after the unit has been reset.

Option [041]: Line card number length - Default [0A]

This option is used to determine how many digits from the line card number will be sent to the output. You also have the option of displaying the number in hex or decimal. This option will also determine the Program Option [02]/[102]/[202] with one of the following:

01 Send only one hex digit to the printer or computer output (if you have a 2-digit line card number only the last digit will be sent to the output). If using DNIS replace RRLLL then the output will be 3 digits RRL.

02 Send 2 hex digit line card number to the output. If using DNIS to replace RRLLL then the output will be 4 digits RRL.

03 Send 3 hex digit line card number to the output (leading Zeros will be inserted prior to the line card number) If using DNIS to replace RRLLL then the output will be 5digits RRL.

0A Send 3-digit line card number in decimal and the 2-digit receiver number in decimal. If using DNIS to replace RRLLL then the output will be 5digits RRL (this option will only affect message output for POTS Channels and IP Channel).

0D Send 3-digit line card number in decimal and the 2-digit receiver number in Hex. If using DNIS to replace RRLLL then the output will be 5digits RRL.

NOTE: *When setting this option, the line card Number Length option should always correspond to the number of DNIS digits being received. For example, if 5 digits are being received then the line card Number Length Option should be programmed to 3. This would cause the 5 digits of DNIS DDDDD to overwrite the standard RRL.*

Option [042]: Line card Busy out - Default [00]

This option allows the line card to seize the phone line in case of checksum error after download or when its internal buffer is full after loss of communication with the System. Program with one of the following:

00 The line is seized if any of the conditions mentioned above occur.

01 The line is NOT seized if any of the conditions mentioned above occur. Once the event buffers of the receiver are full, the oldest event in the buffer will be removed to make room for the new event(s).

04 The line will be seized if the automation computer is absent. System will busy out ONLY if the internal computer buffer is full. If there is a loss of printer(s), any new alarms will not be buffered in the internal printer buffer.

05 The line will be seized immediately if there is a loss of automation software or no communication to the CPM.

NOTES:

The status condition will be indicated on the LED even though the unit does not busy out the line. Example – set option to 01 (do not busy out) and have a loss of time present. The status will still be displayed on the status LED, but the system will not busy out.

If the option is programmed to 01, the line card will NOT buffer any new alarms once the internal buffer is full. Setting this option to 01 is NOT RECOMMENDED.

If this 01 is selected, the line card will overwrite the oldest alarm with a new alarm when the internal buffer is full.

Option [043]: Line card Protocol ID - Default: [01]

RS-232 Format

S,0 (zero): protocol number

RR: Receiver number

LLL: Line number

AAAA: Account code, always 0000

Nxxyy = SIA event

[00] - Output for all internal signals is SRRL protocol

SRRLLL[#AAAA|Nxxyy]

[01] - Output for all internal signals is 0RRL (Zero) protocol

0RRLLL[#AAAA|Nxxyy]

Option [044]: Line card Class Field - Default [04]

00 Send "0" in C.L.A.S.S. field of CONCOMM/RBUS packet.

01 Send Receiver Line Card Number (RRLLL) from options in C.L.A.S.S. field of CONCOMM/RBUS packet.

02 Send DNIS in C.L.A.S.S. field of CONCOMM/RBUS packet.

03 Send Caller ID in C.L.A.S.S. field of CONCOMM/RBUS packet.

04 Send whatever option[12] Caller Source is set to in the C.L.A.S.S. field of CONCOMM/RBUS packet.

05 Send the convert data from the DNIS/Caller-ID (combined) Conversion table in the C.L.A.S.S. field of CONCOMM/RBUS packet.

Example: DNIS is: 99802

Automation:

S99802[#1234|NBA0F10]

Printer:

03 Jun 2008 08:33:33 - 03 Jun 2004-08:33:32-01/01-SG -99-802-1234--Alarm Zone

5.3 SG-DRL3/SG-DRL3-2L Static Options: [00] - [2F]

SG-DRL3 Option [00]: Reserved

SG-DRL3-2L Option [100]/[200]: Reserved

SG-DRL3 Option [01]: Line Card Number - Default [01]

SG-DRL3-2L Option [101]/[201]: Line Card Number - Default [01]

The line card Number provides a virtual identification code for each SG-System III module. Hexadecimal numbers '01' to 'FE' can be programmed in Option [01]/[101]/[201] to identify line cards.

SG-DRL3 Option [02]: Line Card Number Length - Default [0A]

This option is used to determine how many digits from the line card number will be sent to the output. You also have the option of displaying the number in hex or decimal.

Program Option [02]/[102]/[202] with one of the following:

01 Send only one hex digit to the printer or computer output (if you have a 2-digit line card number only the last digit will be sent to the output).

02 Send 2 hex digit line card number to the output.

03 Send 3 hex digit line card number to the output (leading Zeros will be inserted prior to the line card number).

0A Send 3-digit line card number as entered (no conversion).

0D Send 3-digit line card number in decimal (conversion from decimal to hex decimal. Receiver number will be outputted as programmed without any conversions).

NOTE: *When setting this option, the line card Number Length option should always correspond to the number of DNIS digits being received. For example, if 5-digits are being received then the line card Number Length Option should be programmed to 3. This would cause the 5 digits of DNIS DDDDD to overwrite the standard RRL.*

SG-DRL3 Option [03]: Internal messages RS-232 - Default [01]

When this option is programmed as '00', the channel will output its internal messages in the following format:

SRRLLL[#AAAA|Nxxyy]

If it is programmed as '01' internal messages will be output as

0RRLLL[#AAAA|Nxxyy]

Where

S, 0 (zero) = Protocol number

RR = Receiver number

LLL = Line number

AAAA = Account code, always 0000

Nxxyy = SIA event

SG-DRL3 Option [04]: 2-Way Audio Activation Time - Default [00]

This option determines how long, in 10-second increments, the 2-way audio function will be active once it is initiated. At the end of this time, the line card will hang up the line. Program a value from "01" to "FF" for 10 seconds to 2550 seconds. Three (3) minutes is the recommended length of time for the 2-way audio activation time. To disable the 2-way audio feature, program Option [04]/[104]/[204] as "00".

NOTES: Enabling 2-way audio will affect NFPA 72 system loading requirements. Refer to Par. 4-5.3.2.2.2 of NFPA 72 for details.

If the alarm panel sends a listen-in code activation request and audio is enabled for this format (Option [7F]/[17F]/[27F] or [B0]/[10B]/[20B]), the receiver will remain in 2-way voice for a period of 60 seconds even if the activation time is not programmed.

For UL Listed products, the permitted setting is 00.

SG-DRL3 Option [05]: Pre-H.S. Duration - Default [1A]

SG-DRL3-2L Option [105]/[205]: Pre-H.S. Duration - Default [1A]

When the line card seizes the line, it will wait the time programmed at Option [05]/[105]/[205]; then send the first handshake. The value programmed (hex) at this location will be multiplied by 100 ms. [e.g., 100 ms., 200 ms.] The default is 0A, for 1000ms (100ms x default value).

The minimum time is 1 second. If the option is programmed with any value lower than 0A, the line card will use a 1 second delay. The maximum time for this option is 5 seconds (option programmed for 0x32) Option value higher than 0x32 will use a 5 second delay.

SG-DRL3 Options [06] - [08]: Reserved

SG-DRL3-2L Options [106]/[206] - [108]/[208]: Reserved

SG-DRL3 Option [09]: First Ring Length - Default [05]

SG-DRL3-2L Option [109]/[209]: First Ring Length - Default [05]

In order for the line card to detect an incoming ring, the ring signal must be ON for a minimum amount of time.

This option allows the user to change the minimum amount of time the ring signal must be ON before the receiver will detect a valid ring length.

The minimum ring duration allowed is 200 ms which corresponds to a value of 02 (200 ms).

Values programmed will be multiplied by 100 ms. Values of 00 and 01 give the default of 1 second.

SG-DRL3 Option [0A]: Format ID Output - Default [00]

SG-DRL3-2L Option [10A]/[20A]: Format ID Output - Default [00]

This option will allow the line card to output the format ID and profile that was used to receive the call. This output is to the printer only.

The format for the output:

27 Nov 2009-18:51:25-01/06-SG -(PP)FF-RR-LLL-EVENT MESSAGE
Where PP is the profile number and FF is the format ID.

Format ID List

Format Description	Format ID	Format Description	Format ID
3/8 ACRON	1	3/16/1 Scantronics Super Fast	2A
4/8 ACRON	2	4/16/1 Scantronics Super Fast	2B
4/1 Express	10	5/16/1 Scantronics Super Fast	2C
4/2 Express	11	6/16/1 Scantronics Super Fast	2D
3/8/1 Ademco Super Fast	13	ITI Generic	33
4/8/1 Ademco Super Fast	14	ITI Commader III	34
4/8/1 with Checksum Ademco Super Fast	15	ITI Commader	36
		ITI Security Pro	37
Contact ID (4-Digit Account)	16	ITI Caretaker Plus	38
Bellcore Caller-ID	1B	ITI SX V	39
Bellcore Caller-Name	1D	ITI Commander 2000	3A
DMP Serial 1	21	CFSK	40
DMP Serial 3	22	Surtec	4A
4/3/1 FBI Super Fast	24	Contact ID (10-Digit Account)	4B
		BFSK	4C
4/3/1 with Checksum FBI Super Fast	25	3/1 Pulse	4D
		3/2 Pulse	4E
2/8/1 Scantronics Super Fast	26	4/1 Pulse	4F
5/8/1 Scantronics Super Fast	27	3/1 Extended Pulse	50
6/8/1 Scantronics Super Fast	28	3/1 Partial Extended Pulse	51
2/16/1 Scantronics Super Fast	29		

4/1 Partial Extended Pulse	52	4/2 Sur-Gard	7F
4/1 Extended Pulse	53	4/2 with Checksum Sur-Gard	7F
4/2 Pulse	54		
4/2 Extended Pulse	55	4/3 Sur-Gard	80
5/1 Pulse	56	4/3 with Checksum Sur-Gard	80
Modem IIA	58		
Modem IIB	59	4/1 Varitech	85
Modem II Generic	5a	4/2 Varitech	86
Modem IIE or IIIa2	5b	Westec 1	8A
4/3 Sescoa Super Speed	69	Westec 2	8B
Sescoa Open/Close Super Speed	6A	Westec 3	8C
		Westec 5	8D
SIA FSK Level 1, 2 and 3	6B	Westec 6	8E
Silent Knight FSK0	7A	CESA	90
Silent Knight FSK1	7B	OUTEL	91
Silent Knight FSK2 o/p Type 1	7C	ROBOFON	92
		VONKOR	95
Silent Knight FSK2 o/p Type 2	7D	ADCOR	98
		Sur-Gard Generic Internal Messages	FF
4/1 Partial Extended Pulse	52	4/2 Sur-Gard	7F

SG-DRL3 Option [0B]: Reserved

SG-DRL3-2L Option [10B]/[20B]: Reserved

SG-DRL3 Option [0C]: DTMF Cadence - Default [00]

SG-DRL3-2L Option [10C]/[20C]: DTMF Cadence - Default [00]

This option will allow the outputted DTMF Cadence (on and off time) to be programmed in milliseconds. The DTMF Cadence option will only be used for outbound dialling when performing a 2-way audio and line test. This will not affect DTMF for communication format detection or for Contact ID generation (line test mode). DTMF on - off time tolerance is programming value +/- 5 ms.

The upper nibble of the option will control the DTMF on time - the lower nibble will control the DTMF off time, in 25mS increments from 100mS. The Default setting of 00 will have 100/100ms cadence.

Nibble Value	Time (ms)	Nibble Value	Time (ms)
0	100	6	150
1	25	7	175
2	50	8	200
3	75	9	225
4	100	A	250
5	125	5	125

Example:

To have a DTMF cadence of 150mS (on and off time) program the option with 66. This option will also allow for cadence settings that are not symmetrical. If desired, the on and off times may be different - Example: to have DTMF on time of 75mS and an off time of 200mS, program the option as 38.

SG-DRL3 Option [0D]: Line Conditions - Default [000]

SG-DRL3-2L Option [10D]/[20D]: Line Conditions - Default [000]

Line Conditions is a bit enabled option - If programmed as 00, the line card will detect a single ring. If bit 1 is programmed the line card will detect the double ring. If bit 2 is enabled the line card will perform a Hook Flash as the end of the call before going on-hook to terminate the call. When the Hook Flash is performed, a 500mS delay shall be applied prior to the line card going on-hook.

Bit #	Option Description
All off	Single ring with no Hook Flash
Bit 1	Double ring detection enabled
Bit 2	Reserved - Line Reversal for BABT
Bit 3	Hook Flash on call end enabled. The Hook Flash performed on the call end will follow the time set in the Hook Flash option [11]. If 2-way options are enabled to use Hook Flash then the 2-way session will complete and the Hook Flash for hang-up will be performed.

Examples:

Program the option with 00 for single ring and no Hook Flash for hang-up.

Program the option with 01 (bit 1 set) for double ring and no Hook Flash on hang-up.

Program the option with 04 (bit 3 set) bit for single ring and Hook Flash for hang-up.

Program the option with 05 (bit 1 and 3 set) for double ring and Hook Flash for hang-up.

SG-DRL3 Option [0E]: Backup Phone Line Option - Default [00]

Enables or disables the Backup line of each channel. If programmed as 00, the option is disabled. If programmed as 01, the backup is enabled and, if a line fault occurs on the primary channel, the line card will switch to the auxiliary line and allow normal operation.

In order to program the option for use on either channel the following programming can be done:

- 01 - Backup Channel enabled
- 00- Backup Channel Disabled

NOTE: If this option is turned on, then 2-way audio will not be available through the auxiliary channel. If 2-way audio is required, the Hook Flash operation of the channel must be used. With this option enabled, the LCD Line Fault message will change.

The table below shows how the line fault LED will operate with this option enabled.

Primary Channel	Auxiliary Channel	Line Fault LED	Active Line
Not in Line Fault	Not in Line Fault	OFF	Primary
Not in Line Fault	Not in Line Fault	OFF	Primary
In Line Fault	In Line Fault	OFF	Auxiliary
In Line Fault	In Line Fault	ON	None

If the primary line goes into line fault, the line card will then switch to the Backup line and continue normal operation. If at any time the primary line is restored, the line card will finish its on-line operation (if it is currently communicating with a panel), and upon completion will switch back to the primary line.

Line Fault and Line Restoral Messages:

The line fault and line restoral messages for the primary line are the same as the backup (computer and printer messages). The line fault and line restoral messages for the auxiliary line are as indicated below:

The computer message for a line fault and line restoral on the auxiliary line are the same as the primary line.

The printer messages for the line fault and line restoral on the auxiliary line are different in that they have line number '2' in them.

Nov 17 2007 - 08: 08: 35-SS/OO-SG-RR-LLL-0000-PHONE LINE 2 RESTORE
Nov 17 2007- 08: 08: 35-SS/OO-SG-RR-LLL-0000-PHONE LINE 2 TROUBLE

SG-DRL3 Options [0F] -[10]: Reserved

SG-DRL3-2L Options [10F]/[20F] -[110]/[210]: Reserved

SG-DRL3 Option [11]: Hook Flash Enable/Disable - Default [00]

SG-DRL3-2L Option [111]/[211]: Hook Flash Enable/Disable - Default [00]

Enables or disables ability to Hook Flash the phone line and determines its duration in increments of 10 ms.

If programmed as 00, the option is disabled. If set to anything else, multiply the decimal equivalent of the hex value by 10 ms and that is the duration. For example, if Hook Flash time of 500 ms is wanted, program Option 2A to 32 hex.

500 ms / 10	= 50
50 Dec	= 32 hex

SG-DRL3 Option [12]: Caller Source ID Option - Default [00]

SG-DRL3-2L Option [112]/[212]: Caller Source ID Option - Default [00]

This option allows the line card to receive Caller Identification data or DNIS that is transmitted after the first ring on the telephone line. The appropriate service must be available and requested from the telephone company for this feature to be operational.

- 00 Disabled
- 01 Standard Bellcore Caller ID
- 0X Receive DTMF DNIS (the low nibble X is 4 to A)
- 10 Select ETSI DTMF Caller ID. In this mode the primary incoming line must be connected to both primary and backup connectors for phone line detection. The aux line will detect the DTMF caller ID and must be sent pre line ring.
- 11 Select ETSI DTMF Caller ID or BELL CORE. In this mode the primary incoming line must be connected to both primary and backup connectors for phone line detection. The aux line will detect the DTMF caller ID and must be sent pre line ring.

- 2X Receive X DNIS and ANI in <DNIS>T<ANI>T format, where T=terminator digit (any hex digit B - F). The low nibble X must be 4 to A.
- 4X Receive ANI and X DNIS in <ANI>T<DNIS>T format, where T=terminator digit (any hex digit B - F) . The low nibble X must be 4 to A.

NOTE: Option [27]: Caller Source Process must be set to the desired caller ID/DNIS length for this option to function correctly.

General messages other than Caller ID or DNIS may be received and decoded by the receiver.

- Private Call:** An anonymous indication is received instead of the originating telephone number.
- No Call No.:** An out-of-area or unavailable indication is received instead of the originating telephone number.
- Unknown Call:** The originating telephone number has not been received or was not transmitted.

SG-DRL3 Option [13]: Caller Source to SG Automation - Default [00]

SG-DRL3-2L Option [113]/[213]: Caller Source to SG Automation - Default [00]

This option allows the transmission of the Caller Identification or ANI, to the automation output. Program Option [13]/[103]/[203] as one of the following:

Protocol	Format	
00	-	Do not send to the automation
01	4RRLL	Send to the automation (North American Caller ID)
02	URRLLL	Send to the computer (International Caller ID)
04	uRRLL	Send ANI information to the automation
05	uRRLLL	Calling Name protocol identifier

NOTE: Option [12] must be programmed for Caller ID (01), or ANI, (4x or 8x, where "x" represents the number of DNIS digits).

SG-DRL3 Option [14]: Caller Source to Printer - Default [00]

SG-DRL3-2L Option [114]/[214]: Caller Source to printer - Default [00]

This option allows the transmission of the Caller Identification or ANI, to the printer output. Program Option [14]/[104]/[204] as one of the following:

Protocol	Format	
00	-	Do not send to the printer
01	4RRLL	Send to the printer; each alarm will print an extra line, showing the Caller ID (North American Caller ID)
04	uRRLL	Send to the printer; each alarm will print an extra line, showing the ANI number

NOTE: Option [12]/[112]/[212] must be programmed for Caller ID (01), or ANI, (4x or 8x, where "x" represents the number of DNIS digits).

SG-DRL3 Options [15] - [18]: Reserved

SG-DRL3-2L Options [115]/[215] - [118]: Reserved

SG-DRL3 Option [19]: Fault Call Counter - Default [00]

SG-DRL3-2L Option [119]/[219]: Fault Call Counter - Default [00]

This option is used for limiting the number of fault call messages (communication fail) that are sent to the printer and computer. 00: (default) will send a fault call alarm for every 10 fault calls. On power-up, the channel will send on the first fault call, and then every 10 afterwards.

- 00 Send fault call message every 10th fault call that occurs.
- 01 Send a fault call message to the automation and printer on each fault call.

SG-DRL3 Option [1A]: DNIS Sensitivity - Default [00]

SG-DRL3-2L Option [11A]/[21A]: DNIS Sensitivity - Default [00]

Sometimes the DNIS levels are much different than the phone line conditions, and therefore it may be necessary to configure the sensitivity during the reception of DNIS.

The basic formula that the DSP uses is:
cutoff level in db = 20log((value/15)^0.5) - 42

DNIS Sensitivity Option[A]

0x00 = -35db (value of 3F is written to DSP) (Default)

0x0f = -42db to 0db

0x3f = -35db to 0db

0xff = -29db to 0db

NOTE: Do not change this option unless instructed to do so by DSC Technical Support.

SG-DRL3 Option [1B]: Reserved

SG-DRL3-2L Option [11B]/[21B]: Reserved

SG-DRL3 Option [1C]: Busy Out - Default [00]

This option allows the line card to seize the phone line in case of checksum error after download or when its internal buffer is full after loss of communication with the System. Program Option [1C]/[11C]/[21C] with one of the following:

- 00 The line is seized if any of the conditions mentioned above occurs.
- 01 The line is NOT seized if any of the conditions mentioned above occurs.
- 04 The line will be seized if the automation computer is absent. System ONLY if the internal computer buffer is full. If there is a loss of printer(s), any new alarms will not be buffered in the internal printer buffer.
- 05 The line will be seized immediately if there is a loss of automation software or no communication to the (Note: the line card has two independent printer and computer buffers).

NOTE: If the option is programmed to 01, the line card will NOT buffer any new alarms once the internal buffer is full. Setting Option [1C]/[11C]/[21C] to 01 is NOT RECOMMENDED.

Detailed Description:

Reasons for seizing phone line:

Reason	LED Status Flashes
System absent	1
On power up, the line cards clock is not set, so it cannot put a timestamp on events coming in.	2
Command to disable line card was sent (downloading).	3
Computer or printer buffer full (if 4 then any buffer full will seize line, if 5 then only computer buffer full will seize line).	4
Checksum failed for any one of the flash files	5
System is in manual mode.	7
System is in Line Test mode	8
Line card in recovery mode	9

SG-DRL3 Option [1D]: Reserved

SG-DRL3-2L Option [11D]/[21D]: Reserved

SG-DRL3 Option [1E]: Reserved

SG-DRL3-2L Option [11E]/[21E]: Reserved

SG-DRL3 Option [1F]: Debug - Default [01]

SG-DRL3-2L Option [11F]/[21F]: Debug - Default [01]

The debug option controls the flow of debug messages to the debug port on the line card.

For Serial communications the baud rate of the debug port is 19200 8N1 with no flow control.

As a general rule, only high priority error type messages will output, independent of what this option is set to.

This option is a bitwise option, meaning more than one option may be turned on at once, although it is not recommended to turn all options on, as it will slow down and could affect the performance of the receiver.

Bit value	Task	Description
01	Enable	Debug mode enabled
02	RBUS	Debug mode for RBUS. All commands sent to/from the line card over RBUS will be outputted when enabled
04	Reserved	For future
08	Reserved	For future
10	Reserved	For future
20	PHONE LINE	Displays the line voltage reading for the channel
40	Time	Debug timestamp on
80	Fast Enable	Fast Debug messages enabled

For each incoming call to the receiver when the debug generates the message ring on primary, the receiver shall also log the firmware version and the DSP version that is currently active on the system.

Data will only be outputted from this debug option if the debug task for the selected debug menu is enabled. This can be done via the serial debug from the console software application.

Example of debug output

```
tfs2 02.621 SW Version:1.11.01.003
tfs2 02.621 DSP Version:1.90.01.045
tfs2 02.621 Ring on Pri CH2 12/1/2009 11:30:2
tfs2 02.621 DSP: Input[0f]
tfs2 03.628 DSP: Output[a1]
tfs2 03.628 sending: 2300Hz for 1000ms
tfs2 05.632 >
tfs2 05.632 6655;1816A2AAAA1E
tfs2 07.028
tfs2 07.028 (16-501002 186655E60200001)
tfs2 07.028 (16-00-01-002-6655-E602-00 PER TEST REPORT 001)
tfs2 07.029 sending: 1400Hz for 800ms
tfs2 11.033 FORMAT IS:DTMF
```

NOTE: Set to 01 to enable. The debug mode should only be used when required and disabled after use.

SG-DRL3 Option [20]: C.L.A.S.S. Field Data - Default [04]

SG-DRL3-2L Option [120]/[220]: C.L.A.S.S. Field Data - Default [04]

- 00 Send "0"s in C.L.A.S.S. field of Con Comm/RBUS packet.
- 01 Send Receiver Line Card Number (RRLLL) from options in C.L.A.S.S. field of Con Comm/RBUS packet.
- 02 Send DNIS in C.L.A.S.S. field of Con Comm/RBUS packet.
- 03 Send Caller ID in C.L.A.S.S. field of Con Comm/RBUS packet.
- 04 Send whatever option[12] Caller Source is set to in the C.L.A.S.S. field of Con Comm/RBUS packet.
- 05 Send the convert data from the DNIS/Caller-ID (combined) Conversion table in the C.L.A.S.S. field of Con comm/RBUS packet.

Example: DNIS is: 99802

Automation:

S99802[#1234]NBA0F10]

Printer:

03 Jun 2004 08:33:33 - 03 Jun 2004-08:33:32-01/01-SG -99-802-1234--Alarm Zone

SG-DRL3 Options [21]- [24]: Reserved

SG-DRL3-2L Options [121]/[221]- [124]/[224]: Reserved

SG-DRL3 Option [25]: Phone Line Voltage Select

SG-DRL3-2L Option [125]/[225]: Phone Line Voltage Select

Default = 00 (for approx 20V)

To calculate the proper setting, use the following formula:

Phone Line Voltage = 2000 / option [25]/[125]/[225].

The debounce to detect line fault is 5.

Option [25]/[125]/[225] must be between 50 and 250, otherwise the default of 100 (0x64) = 20V will be used.

Note that it is not advised to decrease the Voltage level to < 20V since this affects the timing of ring detection, and may cause the channel not to detect rings.

For example, to set the phone line voltage to 15V:

2000/15 = 133 therefore set Option[25]/[125]/[225] = 0x85.

SG-DRL3 Option [26]: Reserved

SG-DRL3-2L Option [126]/[226]: Reserved

SG-DRL3 Option [27]: Caller Source Process - Default [05]

SG-DRL3-2L Option [127]/[227]: Caller Source Process - Default [05]

This option determines how many digits of Caller ID or DNIS (dependant on Option [12]/[112]/[212]) the receiver will process the number of digits in range from 0x01 to 0x10 hex.

SG-DRL3 Options [28] - [29]: Reserved

SG-DRL3-2L Options [128]/[228] - [129]/[229]: Reserved

SG-DRL3 Option [2A]: Hook Flash Delay - Default [00]

SG-DRL3-2L Option [12A]/[22A]: Hook Flash Delay - Default [00]

This option will control the duration after dialling, before the receiver will go back on hook. The Hook Flash Delay Option contains two levels of resolution controlled by the upper nibble.

00 = no delay

01 - 5F = 100ms to 9500ms.

A1 - AF = 10s to 150s

xx = 9500ms.

Examples:

If Hook Flash Delay time of 500ms is wanted, program option 2A to 05 hex.

If Hook Flash Delay time of 120s is wanted, program option 2A to AC hex.

SG-DRL3 Options [2B]: Reserved

SG-DRL3-2L Options [12B]/[22B]: Reserved

SG-DRL3 Option [2C]: Dialer Presence - Default [00]

SG-DRL3-2L Option [12C]/[22C]: Dialer Presence - Default [00]

- 00 Disabled
- 01 The receiver will begin its handshake sequence only if a valid dialer presence tone is received.
- 02 The receiver will begin its handshake sequence after a valid dialer presence tone is received, or a time-out occurs.

Valid tones are 980Hz, 1300Hz or 1890Hz each are +/- 50Hz, for a minimum of 100ms.

Frequencies slightly outside of this window may work but unreliably. The receiver timeout period for dialer presence detection is 5 seconds. When the Dialer Presence tone option is enabled, the Pre-handshake delay option [05]/[105]/[205] is not functional. This timing is in order to synchronize the handshakes sent by the receiver as to not overlap with a dialer-presence tone that is recurring.

SG-DRL3 Option [2D]: A.H.S. - Default [00]

SG-DRL3-2L Option [12D]/[22D]: A.H.S. - Default [00]

A.H.S., Automatic Handshake Selection is the process of the line card to send a handshake to be used with the ANI. Also included in A.H.S. is the ability for the System to "remember" which handshakes are used for which ANI Caller ID.

The A.H.S. has the ability to be used in conjunction with the DNIS to select a predefined profile based on the DNIS table that is stored in the line card. The handshake is retrieved from the A.H.S. table, and the remainder of the options to be taken from the DNIS profile.

Also, if the panel does not respond to the handshake given by the line card, it will proceed with its handshake sequence from this profile as opposed to the default profile.

- 00 A.H.S. Disable
- 01 A.H.S. enable, 10 digits
- 02 A.H.S. enable international

Call Blocking

When A.H.S. is active at any time the operator may want to use a call blocking type feature for particular customers (i.e. inactive accounts). The operator will be able to manually update the A.H.S. database with the SG-System III Console software. If the operator wishes to call block a particular customer (Caller ID), they would do this by entering for that entry the handshake value of 99. When this is sent to the line card, the line card will release the line as soon as it sees the Caller ID.

Computer Message:

0RRLLL[#0000]BLOCKED CALL

Printer Message:

RRLLL-0000--BLOCKED CALL

SG-DRL3 Option [2E]: DMP Time location Offset - Default [00]

SG-DRL3-2L Option [12E]/[22E]: DMP Time location Offset - Default [00]

NOTE: DMP is not supported by the SG-DRL3-2L.

This option is used when sending the update time and date command to the DMP panels. You will have to provide the Greenwich Mean Time (GMT) offset for the Sur-Gard receiver, starting at GMT and moving westerly across the Earth. For the time zones that do not fall under the 1 hour interval, the option should be left at the Greenwich Mean Time [24] setting.

An Option setting of 00 is disabled - All settings above 24 must act as a disabled state (00).

When the DMP panel calls in and requests a time update, the receiver will respond with its current time and the offset value programmed in this section. The time and date of the receiver with respect to the Greenwich Mean Time (GMT). The gg values in the update time and date command are determined by starting at the GMT and moving westerly across the Earth. The table below will be used to determine the time zone for the option value.

Possible Values	Time Zone Description		Time Zone
	Military	Civilian	
00	Disabled	No time update will be sent to the panels	NA
24	Zulu	Greenwich Mean Time (GMT)	GMT (0)
23	Alpha	Central Europe Time (CET) Middle European Time (MET)	GMT + 1
22	Bravo	Eastern Europe Time (EET)	GMT + 2
21	Charlie	Baghdad Time (BT)	GMT + 3
20	Delta	Gulf Standard Time (GST)	GMT + 4
19	Echo	Pakistan Time (PKT)	GMT + 5
18	Foxtrot	Bangladesh Time (BDT)	GMT + 6
17	Golf	Java Time (JT)	GMT + 7
16	Hotel	China Coast Time (CCT)	GMT + 8
15	India	Japan Standard Time (JST)	GMT + 9
14	Kilo	Guam Standard Time (GST)	GMT + 10
13	Lima	Solomon Islands Time (SBT)	GMT + 11
12	Mike	New Zealand Standard Time (NZST)	GMT + 12
01	November	Cape Verde Time (CVT)	GMT - 1
02	Oscar	Greenland Eastern Standard Time (VTZ)	GMT - 2
03	Papa	Eastern Brazilian Standard Time (BST)	GMT - 3
04	Quebec	Atlantic Standard Time (AST)	GMT - 4
05	Romeo	Eastern Standard Time (EST)	GMT - 5
06	Sierra	Central Standard Time (CST)	GMT - 6
07	Tango	Mountain Standard Time (MST)	GMT - 7
08	Uniform	Pacific Standard Time (PST)	GMT - 8
09	Victor	Alaska Standard Time (AKST)	GMT - 9
10	Whiskey	Hawaii Standard Time (HST)	GMT - 10
11	X-Ray	Nome Time (NT)	GMT - 11

SG-DRL3 Option [2F]: Online Time Out - Default [1E]

SG-DRL3-2L Option [12F]/[22F]: Online Time Out - Default [1E]

The Online Time Out option hangs up after a predetermined time delay. Time Out range can be programmed from 01 to 255 seconds (Hex 01 - FF) or until the call is completed by the panel (Hex 00). When time out occurs, the line card hangs up and generates a signal to the printer and to the automation (SIA identifier YS).

For Example:

Printer Message: "DRL Online Time-Out"

Automation: NYS0102 (shelf 01, slot 02).

00 = Disabled.

xx = Maximum time in seconds before the receiver will automatically force termination of a call.

NOTE: Depending on the order of handshakes used, the default online timeout of 30 seconds may not allow sufficient time for all handshakes to be sent before timeout occurs. This time may need to be extended to use these handshakes.

For UL Listed products, the permitted setting is 00 (30s).

5.4 SG-DRL3/SG-DRI3-2L Dynamic Options: [30]/[130]/[230] - [3F]/[13F]/[23F]

SG-DRL3 Options [30] - [3F]: 3/1 - 4/1 Digit 0-F

SG-DRL3-2L Options [130]/[230] - [13F]/[23F]: 3/1 - 4/1 Digit 0-F

The line card uses a unique Sur-Gard communication format to transmit data through the System to the central station computer. Event codes corresponding to alarm codes in 10 to 40 Baud formats and DTMF 4/1 to 4/3 formats are used in this unique format to enable the computer software to determine alarm types.

The receiver will use the last digit of data received in 3/1 and 4/1 formats to determine the computer event code. The event code will then be transmitted to the central station computer. Refer to the Decoding Library for the complete set of event codes used by the line card. In Sections [30] through [3F], program ASCII codes according to the Decoding Library.

Do **NOT** use values other than 20-7F (ASCII).

SG-DRL3 Options [40] - [4F]: 3/2 - 4/2 Digit 0-F

SG-DRL3 Options [140]/[240] - [14F]/[24F]: 3/2 - 4/2 Digit 0-F

Defaults:

Option	Value	Code
40 - 48	41	A
49	52	R
4A	41	A
4B	4F	O
4C	43	C
4D	5C	\
4E	52	R
4F	54	T

The SG-System III will use the first digit following the account code in 4/2, 3/1 extended or 3/2 formats to determine the computer event code. The event code will then be transmitted to the central station computer. Refer to the Decoding Library for the complete set of event codes used by the channel.

In Sections [40] through [4F], program ASCII codes according to the Decoding Library.

Do **NOT** use values other than 20-7F (ASCII).

SG-DRL3 Options [50] - [5F]: 4/3 Digit 0-F

SG-DRL3-2L Options [150]/[250] - [15F]/[25F]: 4/3 Digit 0-F

Defaults:

Option	Value	Code
50 - 58	41	A
59	52	R
5A	41	A
5B	4F	O
5C	43	C
5D	5C	\
5E	52	R
5F	54	T

The SG-System III will use the fifth digit of data received in 4/3 formats to determine the message and event code. The event code will then be transmitted to the central station computer. Refer to the Decoding Library for the complete set of messages and event codes used by the line card. In Sections [50] through [5F], program ASCII codes according to the **Decoding Library**.

Do **NOT** use values other than 20-7F (ASCII).

SG-DRL3 Options [60] - [6F]: Printer Words

SG-DRL3-2L Options [160]/[260] - [16F]/[26F]: Printer Words

Defaults:

Option	Value	Word
60	F2	PERIODIC TEST REPORT
61	OA	FIRE ALARM
62	14	PANIC ALARM
66	1E	BURGLARY
64	63	CLOSING
65	62	OPENING
66	E5	SERVICE
67	00	MEDICAL*
68	E4	MESSAGE
69	61	RESTORE
6A	F2	PERIODIC TEST REPORT
6B	C6	GROUP CLOSING
6C	C7	GROUP OPENING
6D	E6	ZONE BYPASS
6E	50	SYSTEM TROUBLE
6F	A6	CANCEL

**Use only with Model SG-System III CE. SG-System III CE is not UL Listed.*

Refer also to the Library Select Option [71]. The English Printer Library is provided and can be selected by programming the event codes to the corresponding word.

For example, if the words 'exit alarm' are required when the alarm code 1 is received in 3/1 (or 4/1 formats), Option [61] must be programmed as '90'.

Refer to Appendix A for a list of available words.

SG-DRL3 Option [70]: Automation Common Event Code - Default [00]

SG-DRL3-2L Option [170]/[270]: Automation Common Event Code - Default [00]

Some central station software packages are unable to process an alarm using the event codes listed in the Decoding Library. Where a central station monitors thousands of accounts belonging to different companies, the same reporting codes may have different meanings for different companies. Because of this, the individual event codes in

Options [30]/[130]/[230] through [5F]/[15F]/[25F] cannot accurately represent the alarm condition. To overcome this, Option [70]/[170]/[270] may be programmed as indicated below:

Program Operation:

Setting	Description
00	Use individual event codes to computer.
20, 30-39 & 41-5A	Use common event codes (space, 0-9, A-Z). When using common event codes, DSC recommends that either hexadecimal code '5A' (ASCII 'Z') or hexadecimal code '41' (ASCII 'A') be used. The 'Space' character (Hex 20) can be used as the common event code with certain automation software packages to avoid account code database changes when switching over from other brand receivers to the Sur-Gard receiver.
80-DF	'0'-'9', 'A'-'Z' with the most significant bit set). This range will function in the same way as 30-39, 41-5A, with the exception that, for the Superfast Ademco Format, the Printer Message text will not be output.

For example: "01-002-1234-A4-".

SG-DRL3 Option [71]: Library Select - Default [04]

SG-DRL3-2L Option [171]/[270]: Library Select - Default [04]

Determines how to use Printer Words Options.

- 00 No printer words.
- 01 Printer words options used for 1-digit reporting code formats only; other will use pre-defined library.
- 02 Printer words options used for 2-digit reporting code formats only; other will use pre-defined library.
- 03 Printer words options used for 3-digit reporting code formats only; other will use pre-defined library.
- 04 Printer words options used for 1-digit and 2-digit reporting code formats only; other will use pre-defined library.
- 05 Printer words options used for 1-digit, 2-digit and 3-digit reporting code formats.

NOTE: Option [71] is ignored when using SIA, ITI, Contact-ID, ACRON, MODEM II, MODEM IIE, MODEM IIIa², FBI Super-Fast, BFSK, ADEMCO Super Fast and SK FSK 1, 2 formats.

SG-DRL3 Option [72]: SIA Option - Default [00000000]

SG-DRL3-2L Option [172]/[272]: SIA Option - Default [00000000]

This option is a bit selectable Option meaning some or all of these choices may be enabled. For example, to enable "Force SIA Zone Number", and "Convert Pulse formats to SIA", set Option [72]/[172]/[272]=05. To enable only "Convert Pulse to SIA" and "Convert BFSK to SIA" set Option[72]=0C.

Bit 0 - Force SIA Zone Number.

The receiver will decode SIA Alarms sent without Zone numbers and add '00' as the zone number to the automation output:

Example: [#1234|NriBA] becomes [#1234|NriBA00]

Example: [#1234|NBA/BH] become [#1234|NBA00/BH00]

Bit 1 - Convert SIA Account A's.

Any Account Digits received as 'A' will be converted to '0'.

Example: [#A123|NriBA01] becomes [#0123|NriBA01]

Bit 2 - Convert Pulse formats to SIA.

All Pulse Format Printer and Computer outputs will be converted to a SIA format, in a two step conversion process.

The automation Output will use the Protocol ID of 'R'.

First the type of alarm is determined by Options [30]/[130]/[230]-[5F]/[15F]/[25F], [70]/[170]/[270].

Secondly the type of alarm is mapped to a SIA output as per the following table.

Example:

1234A1 becomes '1234 A 1' becomes [#1234|NBA1]

Value	Codes	SIA
41	A	BA
42	B	BA
43	C	CL
46	F	FA
48	H	HA
4F	O	OP
4D	M	MA
50	P	PA
52	R	BR
54	T	TA
5C	\	OC
62	b	BR
66	f	FH
68	h	HH
6D	m	MH
70	p	PH
74	t	TH
7C		UB

Values programmed in Options [30]/[130]/[230]-[5F]/[15F]/[25F], [70]/[170]/[270] other than in this table will default to UAxx with Undecoded Alarm.

Bit 3 - Convert BFSK format to SIA.

The BFSK outputs will be converted to a SIA format. The automation Output will use the Protocol ID of 'R'.

When this option is enabled it has precedence over the BFSK RS232 Option [A4]/[1A4]/[2A4]. The Accounts 3/x to 4/x Option [76]/[176]/[276] may be used to insert a leading 0 to the account code.

Example: [#123]NFA1]

Bit 4 - Convert comma (,) to forward slash (/)

When enabled, any comma's will be converted to a forward slash.

Example: [#1234]NBA1,2,3 becomes [#1234]NBA1/2/3]

Bit 5 - SIA Recovery

Some older SIA panels require that all blocks of the call be NACK'd for the call to be complete or it would assume that if one block was acknowledged then all blocks were correctly acknowledged, and not resend the blocks that were NACK'd. This option will turn off the functionality where, if one block is NACK'd, then all blocks (regardless if they are correct or not) will be NACK'd. In order to disable the SIA recovery option, disable this bit option (default setting). By disabling the SIA recovery, the receiver will send Acknowledgement signals for the blocks that require it and NACK the ones that will require it.

To enable the SIA recovery set bit 5 to 1. If a signal has any portion of the call NACK'd then the entire call will receive a NACK. Please contact technical support for more information and updates to the list of panels affected.

Bit 6 - Pulse to SIA Hex zone numbers

This option is to be used if it is desired to have pulse conversion digits that are starting with HEX output a zone number in SIA. This option functions the same as "Convert Pulse formats to SIA" Option [172]/[272] - bit 2, but will also append a zone number when the pulse event code starts with a Hex Digit.

Examples - with option 72 bit 2 and 6 enabled (Option [72]/[172]/[272] = 44)

1 - Pulse signal received 1234 41

Printer Output 1234-41-BA41

Automation put [#1234]NBA41]

2 - Pulse signal received 1234 B2

Printer Output 1234-B2-OPB2

Automation put [#1234]NOPB2]

2 - Pulse signal received 1234 3C

Printer Output 1234-3C-BA3C

Automation put [#1234]NBA3C]

Setting this option does not affect the output of pulse signals converted to SIA that did not start with a HEX digit.

Bit 7 - Brinks Recovery

When enabled the line card will not check for an ITI carrier on a full duplex SIA (0xfc) handshake

SG-DRL3 Option [73]: Input/Output Sensitivity - Default [15]

SG-DRL3-2L Option [173]/[273]: Input/Output Sensitivity - Default [15]

All Values are approximate. The input sensitivity is programmed by the processor into the DSP on every call.

Option 73 will have the dual purpose of setting the DSP output level and the DSP input level.

The upper nibble will set the input sensitivity of the DSP as described by the following:

0x07 -46dBm	0x3F -35dBm
0x1F -40dBm	0x5F -28dBm

For example, no error occurs if the sensitivity is set to 2F. The actual value would be the closest of higher values and in this case 3F (or -35 dBm).

The max output level shall be XB in order to prevent signal clipping for the 1400Hz frequencies. If the user selects XA then the line card shall use the setting XB.

SG-DRL3 Option [74]: Equivalent Line Number - Default [00]

SG-DRL3-2L Option [174]/[274]: Equivalent Line Number - Default [00]

The equivalent line number is used with the receiver number for sending signals to the central station software. This option may be used if there is no DNIS number being received by the line card.

SG-DRL3 Option [75]: Receiver Number - Default [01]

SG-DRL3-2L Option [175]/[275]: Receiver Number - Default [01]

The receiver number is used for sending signals to the central station software. Refer to the manuals for any central station automation software being used to determine if there are any special requirements for this number. Also, check the numbers used for any other receivers in the station to ensure that numbers are not duplicated.

SG-DRL3 Option [76]: Accounts 3/x to 4/x - Default [00]

SG-DRL3-2L Option [176]/[276]: Accounts 3/x to 4/x - Default [00]

00 - Disabled, if the alarm is reported in 3/1, 3/1 extended, BFSK, 3/2 or 3/8 ACRON formats, a leading space will be communicated in front of the 3-digit account codes.

Ex: 1RRLLSsssssAAAAsXsssY[DC4]

01 - If the alarm is reported in 3/1, 3/1 extended, 3/2 or 3/8 ACRON formats, a leading '0' (zero) will be communicated in front of the 3-digit account codes.

Ex: 1RRLLSsssss0AAAAsXsssY[DC4]

02 - Alarms communicated to the computer. If the alarm is reported in 3/1, 3/1 extended, 3/2 or 3/8 ACRON formats, a leading '0' (zero) will be communicated in front of the 3-digit Account. And a '0' (zero) will be communicated in front of the 1-digit alarm code for the above formats as well as 4/1 format.

Ex: 1011Ssssss0AAAAsXsss0Y[DC4]

04 - If the panel is reported in SIA two leading '0' (zeros) will be communicated in front of the 3-digit account.

EX: S1011[#00AAA]Nri0/FH00]

05 - If the alarm is reported in 3/1, 3/1 extended, 3/2 BFSK, SIA, 3,8 ACRON formats then a leading '0' (zero) will be communicated in front of the 3-digit account.

If the panel is reported in SIA, two leading '00' (zeros) will be communicated in front of the 3-digit account.

06 - If the alarm is reported in 3/1, 3/1 extended, 3/2 BFSK, SIA, 3,8 ACRON formats then a leading '0' (zero) will be communicated in front of the 3-digit account and a '0' (zero) will be communicated in front of the 1-digit alarm code.

07 - If the alarm is reported in 3/1, 3/1 extended, SIA, 3/2 BFSK, 3,8 ACRON formats then a leading '0' (zero) will be communicated in front of the 3-digit account.

SG-DRL3 Option [77]: Digit Replace - Default [00]

SG-DRL3-2L Option [177]/[277]: Digit Replace - Default [00]

This option works in conjunction with Option [A2]/[1A2]/[2A2]. When Option [A2]/[1A2]/[2A2] is enabled and Option [77]/[177]/[277] is programmed with an ASCII value, the receiver will replace or insert an account code digit. Option [A2]/[1A2]/[2A2] determines how to replace or insert a digit.

To replace a digit, set Option [A2]/[1A2]/[2A2] to 0x where x is the digit to be replaced. To insert a digit, set Option [A2]/[1A2]/[2A2] to 8x where x is the digit in the account code, after which will be the inserted digit.

Example 1 (replacing):

Option 77 is set for 41 and Option A2 is set for 01:

Account code is:

9876 1RRLLSsssssAAAAsXsssYZ

The receiver will do the following. First it will replace the first digit (Option A2=01) of the account code (in this example "9") and replace it with the ASCII value of 41, which is an "A".

New Output:

1RRLLSsssssA876sXsssYZ

Example 2 (inserting):

Option 77 is set to 2D and Option A2 is set for 82:

Account code is:

9876 1RRLLSsssss9876sXsssYZ

The receiver will do the following, it will insert the ASCII value of Option 77, in this case the ASCII value of 2D (2D is a " - ") into position two (Option A2=82), and the account code will shift to the left. Therefore it will convert account code 9876 to 9-876 as indicated below:

1RRLLSsssss9-876sXsssYZ

* This will not affect SIA.

SG-DRL3 Option [78]: Max Inter-digit - Default [00]

SG-DRL3-2L Option [178]/[278]: Max Inter-digit - Default [00]

Certain old dialers may have difficulties in communicating with the line cards. The receiver provides a possible solution by programming this option. This option should be left as a default and should be changed only on the recommendation of a DSC technician. When programmed as 00, the inter-digit time is determined by the Baud rate of the format being used; all other values are in 100 ms. intervals.

- 00 Automatically determine inter-digit by baud rate (Default)
- 01 100 ms
- 02 200 ms
-
- 0A 1000 ms
-FF25000 ms

NOTE: Although this section allows all entries from 00-FF it is not recommended to program this section with a time that exceeds 3000ms (1E Hex).

SG-DRL3 Option [79]: Max Inter-burst - Default [00]

SG-DRL3-2L Option [179]/[279]: Max Inter-burst - Default [00]

Certain old dialers may have difficulties in communicating with the line cards. The receiver provides the possible solution by programming this option. This option should be left as default and should be changed only on the recommendation of a DSC technician. When programmed as 00, the inter-burst has a time of 100 ms, all other values are in 10 ms increments.

- 00 100 ms (default)
- 01 10 ms
- 02 20 ms... and so on

SG-DRL3 Option [7A]: 4 and 5 Digit Account Codes to Activate 2-Way Audio - Default [00]

SG-DRL3-2L Option [17A]/[27A]: 4 and 5 Digit Account Codes to Activate 2-Way Audio - Default [00]

This option determines which account codes will be able to activate the 2-way audio feature. Program the first digits of the desired account codes in Option [7A]/[17A]/[27A].

For example:

To allow all account codes between 1000 and 2FFF to activate the 2-way audio function, program Option [7A]/[17A]/[27A] as '12'.

To allow all account codes between 3000 and 6FFF to activate the 2-way audio function, program Option [7A]/[17A]/[27A] as '36'.

To disable the 2-way audio function, program Option [7A]/[17A]/[27A] as '00'.

NOTE: The Audio Time Option[04]/[104]/[204] or Hook Flash Option [11] must be enabled to activate the 2-Way Audio feature of the line card.

NOTE: Option [7A]/[17A]/[27A] may be used with any formats supported by the receiver.

For UL Listed products, the permitted setting is 00.

SG-DRL3 Option [7B]: 3-digit Account Codes to Activate 2-Way Audio - Default [00]

SG-DRL3-2L Option [17B]/[27B]: 3-Digit Account Codes to Activate 2-Way Audio - Default [00]

This option determines which 3-digit account codes will be able to activate the 2-way audio feature. Program the first digits of the desired account codes in Option [7B]/[17B]/[27B].

For example:

To allow all 3-digit account codes between 200 and 3FF to activate the 2-way audio function, program Option [7B]/[17B]/[27B] as '23'.

To allow all 3-digit account codes between 300 and 6FF to activate the 2-way audio function, program Option [7B]/[17B]/[27B] as '36'.

NOTE: The Audio Time Option[04]/[104]/[204] or Hook Flash Option [11]/[111]/[211] must be enabled to activate the 2-Way Audio feature of the line card.

NOTE: Option [7B]/[17B]/[27B] may be used with any 3-digit account code formats supported by the SG-System III.

For UL Listed products, the permitted setting is 00.

SG-DRL3 Option [7C]: Audio Alarm Code Range - Default [00]

SG-DRL3-2L Option [17C]/[27C]: Audio Alarm Code Range - Default [00]

This option determines the range of alarm codes, which will activate the 2-way audio function. Program the first digit of the desired alarm codes in Option [7C]/[17C]/[27C].

For example:

The receiver will initiate audio by the account range, Options [7A]/[17A]/[27A] and [7B]/[17B]/[27B] or by Option [7C]/[17C]/[27C] ALARM CODE or by both.

If all alarm codes beginning with 6, 7 and 8 are to activate 2-way audio, program Option [7C]/[17C]/[27C] as '68'. Option [7C]/[17C]/[27C] may be used with 10 to 40 Baud formats, DTMF 4/1, 4/2, 4/3 and Contact ID formats.

Program Option [7C]/[17C]/[27C] as '00' to disable this function.

Example:

4/2 format with account code 1234, alarm code 2 on zone 3. (1234-23)

Option [7A]/[17A]/[27A]	Option [7C]/[17C]/[27C]	Switch	Reason (or [7B]/[17B]/[27B]) to Audio
00	1-2	Yes	Alarm code 2 falls within the code range 1-2.
1-1	00	Yes	Account code 1234 falls within the range 1-1.
2-3	00	No	Account code 1234 is outside the range 2-3.
00	3-4	No	Alarm code 2 is outside the range 3-4.
1-2	3-4	No	If both are programmed, both must be good and alarm code 2 is outside the range 3-4.
3-5	1-3	No	Both must be good and account code 1234 is outside the range 3-5.
1-4	1-5	Yes	Alarm code 2 falls within the code range 1-5, account code 1234 falls within the range 1-4.

NOTE: The first digit of the Contact ID event code will also follow option [7C]/[17C]/[27C].

For UL Listed products, the permitted setting is 00.

SG-DRL3 Option [7D]: Audio Zone Code - Default [00]

SG-DRL3-2L Option [17D]/[27D]: Audio Zone Code - Default [00]

Audio zone code is the range of zone codes that will activate audio. The first digit is the lowest code. The second digit indicates the highest zone that will activate audio. Option [7D]/[17D]/[27D] may be used with 10 to 40 Baud formats, DTMF 4/1, 4/2, and 4/3 formats.

NOTE: Option [7D]/[17D]/[27D] Only works for DMP Serial 1 not for DMP Serial 3.

For UL Listed products, the permitted setting is 00.

SG-DRL3 Option [7E] Audio RS-232 - Default [00]

SG-DRL3-2L Option [17E]/[27E] Audio RS-232 - Default [00]

This is the code sent to the automation software that indicates that 2-way audio has been initiated. If this option is set to '00' there will be no audio-initiated message sent to the automation output.

Setting	Description	Automation Output
All Bits set 0	2-way audio message disabled	No Automation Output
Bit 1 set to 1 Bit 3 set to 0 Bit 2 set to 0 Bit 4 set to 0	Outputs automation message with protocol "S"	Send SRLLLL[#AAAA][NLFssoo][DC4]
Bit 1 set to 0 Bit 3 set to 0 Bit 2 set to 1 Bit 4 set to 0	Outputs automation message with protocol "O"	Send ORLLLL[#AAAA][NLFssoo][DC4]
Bit 1 set to 1 Bit 3 set to 1 Bit 2 set to 0 Bit 4 set to 0	Outputs automation message with protocol "S" and adds RRLl to the message as clear text	Send SRLLLL[#AAAA][NLFssoo*RRLL*][DC4]
Bit 1 set to 0 Bit 3 set to 1 Bit 2 set to 1 Bit 4 set to 0	Outputs automation message with protocol "O" and adds RRLl to the message as clear text	Send ORLLLL[#AAAA][NLFssoo*RRLL*][DC4]
Bit 1 set to 1 Bit 3 set to 0 Bit 2 set to 0 Bit 4 set to 1	Outputs automation message with protocol "S" and adds the dialed phone number for the call transfer	SRLLLL[#AAAA][NLFssoo*#NNNNNNNNNNNNNNNN*][DC4]
Bit 1 set to 0 Bit 3 set to 0 Bit 2 set to 1 Bit 4 set to 1	Outputs automation message with protocol "O" and adds the dialed phone number for the call transfer	ORLLLL[#AAAA][NLFssoo*#NNNNNNNNNNNNNNNN*][DC4]
Bit 1 set to 1 Bit 3 set to 1 Bit 2 set to 0 Bit 4 set to 1	Outputs automation message with protocol "S" and adds RRLl and the dialed phone number for the call transfer	SRLLLL[#AAAA][NLFssoo*RRLL#NNNNNNNNNNNNNNNN*][DC4]
Bit 1 set to 0 Bit 3 set to 1 Bit 2 set to 1 Bit 4 set to 1	Outputs automation message with protocol "O" and adds RRLl and the dialed phone number for the call transfer	ORLLLL[#AAAA][NLFssoo*RRLL#NNNNNNNNNNNNNNNN*][DC4]

Where:

ss - is receiver shelf number
 oo - is receiver slot number (which line card)
 RR - is receiver number (from option [75] in hex)
 LL - is line card number (from option [74] in hex)
 # - is a delimiter
 N - is the number dialed from options A8-AF

NOTES:

When programmed with bit 1 and 2 disabled, the feature is disabled.
 When option [74] is disabled (00) it will output 00 in the LL and NOT follow option 01 as the LL.

When enabled, Bit 1 over rides the value of bit 2. If both bit 1 and bit 2 is enabled the output is:

SRLLLL[#AAAA]NLFssoo][DC4]

SG-DRL3 Option [7F]: Audio Format Enable - Default [00]

SG-DRL3-2I Option [17F]/[27f]: Audio Format Enable - Default [00]

This option gives you the ability to enable and disable audio for selected formats. A '1' in the formats bit position will enable the format for audio. A '0' in the formats bit position will disable audio for the format.

Bit 0	Standard 3-digit pulse and DTMF formats
Bit 1	Standard 4 and 5 Digit pulse format
Bit 2	Standard DTMF format
Bit 3	Contact ID format
Bit 4	SIA format
Bit 5	Modem II format
Bit 6	ITI Format
Bit 7	Westec format

For example, if the user wants audio to work only for 3-digit pulse and SIA formats, Option [17F]/[117F]/[217F] would have to be programmed as 11 hex which enables bit 0 and bit 4.

SG-DRL3 Option [80]: Kiss-Off to Hang-up Time - Default [1F]

SG-DRL3-2L Option [180]/[280]: Kiss-Off to Hang-up Time - Default [1F]

This option determines the delay between Kiss-off and the release of the line. The hex value programmed at this location will be converted to decimal and then multiplied by 100 ms to generate the delay.

Example:

Option 80 = 0A hex = 10 decimal * 100 ms = 1000 ms = 1 second delay
 Option 80 = 1F hex = 31 decimal * 100 ms = 3100 ms = 3.1 second delay
 Option 80 = 28 hex = 40 decimal * 100 ms = 4000 ms = 4 second delay

This option only applies to the following formats: Pulse, DTMF, SKFSK, Robofon.

SG-DRL3 Options [81] through [88]: Handshake Selection

SG-DRL3-2L Options [181]/[281] through [88]: Handshake Selection

Default:	[81]	23	[85]	0E
	[82]	14	[86]	0B
	[83]	2D	[87]	00
	[84]	0C	[88]	00

The channel is a multi-format receiver capable of sending several handshakes to a dialer/panel. Often it is important which handshake is sent first. Program Options [81]/[181]/[281] through [88]/[188]/[288] according to your applications.

Note that if AHS is enabled (option [2D]/[12D]/[22D]), the AHS handshake will be sent before the handshakes programmed in options [81]-[88].

Handshake Options:

00	No handshake
14	1400 Hz
0B	Modem II handshake
0C	SIA FSK handshake
0D	Westec handshake
0E	ITI and Modem IIE handshake
0F	DMP handshake (NOTE: DMP is not supported by the SG-DRL3-2L.)
	Robofon handshake
1B	CESA handshake
1C	Outel handshake
1D	Single Dual Tone handshake 1400 Hz/100ms 100ms pause and 2300 Hz/100ms tone with a kiss off of 1400 Hz
1E	Scantronics Dual Tone
1F	Vonk (no handshake)
23	2300Hz
2D	Double dual-tone handshake 1400 Hz/100ms 100ms pause and 2300 Hz/100ms tone with a kiss off of 1400 Hz.

3B	Scancom - single dual tone 1600 Hz/100ms 100ms pause and 2000 Hz/100ms tone with a kiss off of 1600 Hz.
3C	Scancom - single dual tone 2300 Hz/100ms 100 ms pause and 1400 Hz/100ms tone with a kiss off of 1400 Hz.
8D	Single tone - DTMF * handshake/Kiss-off.
EC	SURTEC handshake.
FB	CFSK Full duplex handshake.
FF	Perform inter-handshake time, no tone/frequency sent.
3D	Single dual-tone handshake, DTMF buffering.
4D	Double dual-tone handshake, DTMF buffering.
5D	Single dual-tone handshake, Maximum of 16 Digits DTMF. 1400 Hz/100ms 100ms pause and 2300 Hz/100ms tone with a kiss off of 1400 Hz.
6D	Single Dual Tone, enable Fast DTMF receive mode. 1400 Hz/100ms 100ms pause and 2300 Hz/100ms tone with a kiss off of 1400 Hz.
7D	Double Dual Tone, enable Fast DTMF receive mode. 1400 Hz/100ms 100ms pause and 2300 Hz/100ms tone with a kiss off of 1400 Hz.
98	Do not perform AHS for this ANI number.
99	Immediate hang-up, AHS has blocked it.
BE	1400Hz BFSK only, no pulse.
BF	2300Hz BFSK only, no pulse.
FB	Full duplex CFSK.
FC	Full duplex SIA.
FD	FD-SIA300 - SIA FSK handshake. *
FE	ITI handshake, Modem IIE filter.

All other frequencies can be programmed using the first two digits to represent the 3rd and 4th decimal places (01-29).

***NOTE:** The FD handshake enables changes in the SIA reception that allows panels that are not following the SIA standard to be received more consistently. For a more detailed explanation and any updates to the list of panels affected please contact technical support.

Examples:

10	1000 Hz	18	1800 Hz
14	1400 Hz	23	2300 Hz
16	1600 Hz		

***NOTE:** CESA must be programmed before the ITI and Outel Handshake.

****NOTE:** When supporting the VONK format the VONK handshake should be programmed first.

Additional notes:

When using the Vonk Handshake (1F) it is recommended to program this handshake first (Option[81]/[181]/[281]).
 When using both Outel (1C) and CESA (1B) the Outel is recommended to be programmed first in the handshake order.

SG-DRL3 Options [89] to [90]: Handshake and Kiss-off Duration - Default [00]

SG-DRL3-2L Options [189]/[289] to [190]/[290]: Handshake and Kiss-off

Duration - Default [00]

Some control panels may require a different handshake duration. Each unit has increments of 100 ms, from 100 ms to a maximum of 8.1 seconds. Program Options [88]/[188]/[288] to 90 for the desired duration.

00	1 second
01	100 ms
02	200 ms
03	300 ms
04	400 ms
0A	1 second
0C	1.2 second.... and so on

DSC does not recommend programmed durations longer than 1.5 seconds, as it may not be tolerated by the alarm panel. For special applications, it may be necessary, but any durations higher than 8.1 seconds will not be accurate and may not match the duration programmed.

NOTE: These options will only affect steady tones handshakes.

Option [89]/[189]/[289]: Handshake #1 duration
 Option [8A]/[18A]/[28A]: Handshake #2 duration
 Option [8B]/[18B]/[28B]: Handshake #3 duration
 Option [8C]/[18C]/[28C]: Handshake #4 duration
 Option [8D]/[18D]/[28D]: Handshake #5 duration
 Option [8E]/[18E]/[28E]: Handshake #6 duration
 Option [8F]/[18F]/[28F]: Handshake #7 duration
 Option [90]/[190]/[290]: Handshake #8 duration

SG-DRL3 Option [91]: Inter-Handshake Duration - Default [00]

SG-DRL3-2L Option [191]/[290]: Inter-Handshake Duration - Default [00]

The receiver will usually wait for signals from the control panels for 4 seconds before sending the next handshake, if there are no signals received. In certain applications, control panels cannot wait long enough to get their own handshake especially if the handshake is programmed as the fifth or later handshake.

The maximum time allowed for this section is 09 (9 seconds). Program Option [91]/[191]/[291] with one of the following:

- 00 4-second interval 02 2-second interval
- 01 1-second interval 03 3-second interval

SG-DRL3 Option [92]: Pulse Mode - Default [00]

SG-DRL3-2L Option [192]/[292]: Pulse Mode - Default [00]

- 00 = Standard Pulse Detection
- 01 = 50 Baud Pulse Detection
- 02 = Forced (AAA) Pulse Detection, meaning only PULSE is detected.
- 8x = When this bit is on, it acts as a minimum burst rejection option where x can be 1 to F(1ms to 15 ms) burst duration to reject.

SG-DRL3 Option [93]: Min Audio Tone - Default [00]

SG-DRL3-2L Option [193]/[293]: Min Audio Tone - Default [00]

This option is used for 2-way audio tone detection from specific audio panels. This option should be left as default unless otherwise instructed by DSC Technical Support.

SG-DRL3 Option [94]: Account Digit Stripping - Default [00]

SG-DRL3-2L Option [194]/[294]: Account Digit Stripping - Default [00]

When Option [94]/[194]/[294] is set to 00 it is disabled.

When Option [94]/[194]/[294] is set to 01, the leading digit of a 4-digit account code will be stripped if it is an F.

Standard 4/2 format Output:

1RRLLLsssssssAAAAsXssYZ

Example 1:

Option [94]/[194]/[294] set to 01: Panel account code is F245

104091sssssssF245sXssYZ

If Option [94]/[194]/[294] is set to 01 the 'F' will be replaced by a space.

104091sssssss245sXssYZ

This setting will also enable the receiver to decode special pulse extended-extended formats.

104091sssssss245sXssYZ

If Option 94 is set to 02 than the leading digit of any account code greater than four digits will be stripped if it is a zero.

This option will work with the following formats:

Standard Pulse and DTMF(3/x, 4/x & Extended)

FBI

Ademco Super Fast (4/8/1, 4/8)

Contact ID

ITI

SIA

Modem II

SKFSK

Example 1:

Option 94 set to 02

Panel account code is 0345

104091sssssss0345sXssYZ

New Output:

104091sssssss345sXssYZ

Details on "special pulse extended-extended" formats:

Option [94]/[194]/[294] = 01, This option applies to pulse formats. If any of the reporting code digits are an A they will be reported on the computer and printer as as an A instead of a 0.

4 digits:

If two rounds match, decode the 4 digit pulse extended format in the form of:

26AC x2 =>KO (last digit must be C)

CCC2 x2 =>KO (1st 3 digits must be C)

26AF x2 =>KO (last digit must be F)

FFF2 x2 =>KO (1st 3 digits must be C)

26AC2F2

Otherwise decode as 3-1 extended or normal 3-1, and if the first digit is F strip it off.

5 digits:

If the checksum is good, decode the 5 digit pulse extended format in the form of:

26ACF =>KO (2nd last digit must be C)

CCC27 =>KO (1st 3 digits must be C)

26AFC =>KO (2nd last digit must be F)

FFF2D =>KO (1st 3 digits must be C)

26AC2F2

Otherwise decode as 3-1 extended or normal 3-1, and if the first digit is F strip it off.

Do normal decoding based on options (4-1, 4-1 extended, 3-1 checksum, 3-2) and if the first digit is F strip it off.

6 digits:

If two rounds match, decode the 6 digit pulse extended format in the form of:

F1231F

F1231F =>KO (last two digits must be 1F to 8F)

F12301

F12301 =>KO (last two digits must be 01 to 06)

F123B2

F123B2 =>KO (last two digits must be B0 to BF)

1231F01B2

Otherwise decode as 4-2.

SG-DRL3 Option [95]: 5 and 6 Digit Pulse - Default [00]

SG-DRL3-2L Option [195]/[295]: 5 and 6 Digit Pulse - Default [00]

The Line card cannot distinguish between various 5-digit formats and 6-digit formats. 4/1, 3/2 and 3/1 with checksum cannot be distinguished because all of them contain a total of 5 digits. 4/2 and 5/1 cannot be distinguished because all of them contain a total of 6 digits.

Value	5 Digit Setting	6 Digit Setting
00	select 4/1 format	select 4/2 format
01	select 3/2 format*	select 4/2 format
02	select 3/1 checksum format	select 4/2 format
	select 3/1 checksum format special**	
03	select 4/1 format	select 4/2 format
	select 3/2 format*	
10	select 3/1 checksum format	select 5/1 format***
11	select 3/1 checksum format special**	select 5/1 format***
12		select 5/1 format***
13		select 5/1 format***

***NOTE 1:** The printer messages for the 3/2 format are the same as those used for the 4/2 format.

****NOTE 2:** This selects 3/1 checksum only for 40 baud panels, responding on the 2300Hz handshake. For all other panels, this will be decoded as 4-1.

*****NOTE 3:** The printer messages for the 5/1 format are the same as those used for the 4/1 format.

Automation outputs

1RRLLLsssssssAAAAsEsssZ[DC4] (4/1)

1RRLLLsssssssAAAAsEssYZ[DC4] (3/2)

1RRLLLsssssssAAAAsEsssZ[DC4] (3/1)

1RRLLLsssssssAAAAsEsssZ[DC4] (5/1)

Printer outputs

RR-LLL-AAAA-Z-Message (4/1)

RR-LLL-AAA-YZ-Message (3/2)

RR-LLL-AAA-Z-Message (3/1)

RR-LLL-AAAAA-Z-Message (5/1)

SG-DRL3 Option [96]: 4/1 Extended - Default [00]

SG-DRL3-2L Option [196]/[296]: 4/1 Extended - Default [00]

Program the 4/1 Extended Option as '01' to enable combining 2 round pairs of 4/1 extended format into 4/2 output for reporting to the automation and the printer. For example, with Option [96]/[196]/[296] enabled, the security control panel may transmit the following information:

1234 3
1234 3
3333 1
3333 1

The receiver will interpret this information as: 1234 31.
The default of '00', means 4/1 Extended is disabled.

SG-DRL3 Option [97]: 4/2 Extended - Default [00]

SG-DRL3-2L Option [197]/[297]: 4/2 Extended - Default [00]

Program this option as '01' to combine 2 round pairs of 4/2 extended format into 4/3 output for reporting to the computer and the printer. Program one of the following:

Example 1:

1234 05
1234 05
0505 16
0505 16

The receiver will interpret this information as 1234 516.

Example 2:

1234 03
1234 03
3333 01
3333 01

The receiver will interpret this information as 1234 301.

Note that a longer on-line time is required for this format than for a standard 4/2 format. The default setting for Option [97]/[197]/[297] is '00'; when programmed as '00', the option is disabled.

SG-DRL3 Option [98]: 3/1 Extend - Default [01]

SG-DRL3-2L Option [198]/[293]: 3/1 Extend - Default [01]

Program this option as '01' to combine 2 round pairs of 3/1 extended or 3/1 partial extended format into 3/2 output for reporting to the computer and the printer.

For example, with Option [98]/[198]/[298] enabled, the security control panel may transmit the following information:

123 3
123 3
333 1
333 1

The receiver will interpret this information as: 123 31; the default setting for Option [98]/[198]/[298] is '01'; when programmed as '00', the option is disabled.

SG-DRL3 Option [99]: DTMF 8/9 Digit Formats - Default [00]

SG-DRL3-2L Option [199]/[299]: DTMF 8/9 Digit Formats - Default [00]

This option is used to eliminate decoding conflicts with the 8 and 9 digit DTMF formats. The Sur-Gard DTMF 4/3 with checksum, Ademco 4/1 Express and FBI Super Fast without checksum formats are all 8-digit DTMF formats. Also the Ademco 4/2 Express and the FBI Super Fast formats are both 9-digit DTMF formats. Therefore this option must be programmed to inform the line cards which formats will be decoded if 8 or 9-digit DTMF signals are received. The upper nibble will set the 9-digit DTMF format; whereas, the lower nibble of the option will set the 8-digit DTMF format.

The upper nibble is defined as follows:

0x Auto detection (by format ID) of 4-2 express and FBI formats
1x Ademco 4/2 Express
2x FBI Super Fast

The lower nibble is defined as follows:

x0 Sur-Gard 4/3 with checksum
x1 Ademco 4/1 Express
x2 FBI Super Fast without checksum

Example:

To decode Ademco 4/2 Express and Sur-Gard 4/3 with checksum set Option [99]/[100]/[200] to 11.

To decode FBI Super Fast and Ademco 4/1 Express set Option [99]/[199]/[299] to 22.

SG-DRL3 Option [9A]: Error Counter - Default [00]

SG-DRL3-2L Option [19A]/[29A]: Error Counter - Default [00]

When this option is set, it will configure the number of consecutive bad pulse rounds before the receiver will automatically hang-up.

The default of 00 means this option is disabled and the receiver must wait for the panel to hang-up first.

SG-DRL3 Option [9B]: Echo Canceller - Default [00]

SG-DRL3-2L Option [19B]/[29B]: Echo Canceller - Default [00]

When enabled and an incoming call is answered, the receiver will generate a 2100 Hz tone with 180 degrees phase reversal every 450 ms for 2 seconds to suppress echo cancellation equipment.

00 Disabled
01 Enabled: Enable echo canceller

SG-DRL3 Option [9C]: Acron RS-232 - Default [01]

SG-DRL3-2L Option [19C]/[29C]: Acron RS-232 - Default [01]

When this option is programmed as '00', the receiver will convert the Acron Super Fast format signal into the standard 3/2 or 4/2 format:

1RRLLSsssssAAAAsXssYY[DC4]

Where 1 = protocol number

RR = receiver number

LLL = line number

sssss = spaces

AAAA = account code

X = Event Code

YY = Zone Number

And to the printer with the library text as:

RR-LLL-AAAA-YY-Text

If the Acron options is programmed as '01' the Acron Super Fast format will be sent to the automation as indicated below:

9RRLLSsssAAAACCCCCCCC[DC4]

Where 9 = protocol number

RR = receiver number

LLL = line number

ssss = spaces

AAAA = account code

CCCC = channel 1-4

CCCC = channel 5-8

[DC4] = terminator

And to the printer with no library text as:

RR-LLL-AAAA-CCCCCCC-

SG-DRL3 Option [9D]: MODEM II RS-232 - Default [01]

SG-DRL3-2L Option [19D]/[29D]: MODEM II RS-232 - Default [01]

In order for the SG-System III to receive the Modem II formats, two of the handshakes should be programmed 0B or 0E. The Modem II RS-232 option controls how the receiver will output alarms to the automation. This option is a bit-selectable-option meaning more than one bit may be enabled.

Bit 0: OFF: Select protocol: 1RRLLSsssssAAAAXYYYY[DC4]
ON: Select protocol: 6RRLLSsssssAAAAXYYYY[DC4]

Bit 1: OFF: Do not convert to SIA protocol
ON: Convert Modem II to SIA protocol:
SRLLL[#AAAA|EYZZZ][DC4]

Bit 2: OFF: Do not convert to SIA with Modem II ASCII text blocks.
ON: Convert to SIA protocol with Modem II ASCII text blocks as SRLLL[#AAAA|EYZZZ][DC4] and RRLLL[#AAAA|A...][DC4].

Bit 3: OFF: Only decode the first 4 digits of Modem II account codes even if more than 4 received.
ON: Decode up to 10 digits of Modem II account codes.

The default is 0x01 meaning output with 6RRLLL protocol. Do not convert to SIA, do not process Modem II text blocks, and only decode the first 4 digits of Modem II account codes.

NOTES: The lowest bit will also affect the BFSK format decoding.

Ensure that the automation software supports settings 02 and 06 if the SIA protocol is desired.

SG-DRL3 Option [9E]: Scantronics Select - Default [00]

SG-DRL3-2L Option [19E]/[29E]: Scantronics Select - Default [00]

When this option is programmed as '00', 14-digit DTMF will be decoded as Scantronics 4-8-1 with Checksum.

When this option is programmed as '01', 14-digit DTMF will be decoded as Scantronics 5-8-1.

SG-DRL3 Option [9F]: Ademco High Speed RS-232 - Default [01]

SG-DRL3-2L Option [19F]/[29F]: Ademco High Speed RS-232 - Default [01]

When this option is programmed as '00', the receiver will convert the High Speed format signal into 4/2 format automation:

1RRLLSsssssAAAAsXssYY[DC4]

printer: RR-LLL-AAAA-YY-Alarm

When this option is programmed as '01' the Ademco High Speed will not be decoded, and the received data is passed to the outputs.

8RRLLLAAsCCcCsCCcCsC[DC4]

Where 8 = protocol number

RR = receiver number

LLL = line number

AAAA = account code

CCcC = channel 1-4

s = space

CCcC = channel 5-8

s = space

C = channel 9

[DC4] terminator

On the SG-System III this option also controls the Scantronics formats:

2-8-1,5-8-1,6-8-1 (9-digit channels) and 2-16-1,3-16-1,4-16-1,5-16-1,6-16-1 (17-digit channels).

Refer also to the 11 & 12 digit DTMF Option [A0]/[1A0]/[2A0] for configuring conflicting formats.

When this option is programmed as 00, the SG-System III will convert the outputs in the corresponding 2-2,3-2,4-2,5-2 format:

automation: **1RRLLLSsssAAAAAsXssYY[DC4]**

printer: **RR-LLL-AAAAA-YY-Alarm**

When this option is programmed as '01' the Scantronics formats will not be decoded and the received data is passed to the outputs.

automation:

8RRLLLAAsCCcCsCCcCsC[DC4] (9-digit channels)

8RRLLLAAsCCcCsCCcCsCCcCsCCcCsC[DC4] (17-digit channels)

printer:

RR-LLL-AAAAA--cccccccc (9-digit channels)

RR-LLL-AAAAA--ccccccccccccccc (17-digit channels)

The above examples are shown with 6-digit accounts, for accounts less than this, leading digits are not sent. For example, 2-8-1 will be output as:

8RRLLLAAscccccccc[DC4]

RR-LLL-AA--cccccccc

When this option is programmed as '02', the SG-DRL3 will perform the normal 4-2 conversion using the pre-defined individual event codes, instead of Option [70]/[170]/[270] "Common Event Code". This will not affect other formats (Pulse, ITL, etc) that will use option [70]/[170]/[270].

SG-DRL3 Option [A0]: 11 / 12-Digit DTMF

SG-DRL3-2L Option [1A0]/[2A0]: 11 / 12-Digit DTMF

(Acron, Scantronics or Scancom 433) - Default [00]

When this option is programmed as '00', if 11 or 12-digit DTMF is received, it will be decoded as ACRON Format.

When this option is programmed as '01', if 11 or 12-digit DTMF is received, it will be decoded as SCANTRONICS Format.

When this option is programmed as '02', if 12-digit DTMF is received, it will be decoded as Scancom 433 Format.

	Incoming Format	Decoded Format
00	11-digit DTMF	Acron 3-8
00	12-digit DTMF	Acron 4-8
01	11-digit DTMF	Scantronics 2-8-1
01	12-digit DTMF	Scantronics 3-8-1
02	12-digit DTMF	Scancom 433 4-3-3-FF

SG-DRL3 Option [A1]: FBI RS-232 - Default [01]

SG-DRL3-2L Option [1A1]/[2A1]: FBI RS-232 - Default [01]

To enable the computer for FBI Super Fast protocol, program Option [A1]/[1A1]/[2A1] as '01'. When enabled, the computer output will be as indicated below:

JRRLLLSsssAAAATZZEss[DC4]

Where:

J = FBI protocol identifier

RR = receiver number

LLL = line number

s = spaces

AAAA = account code

T = zone type

ZZ = zone number, in hex.

E = event code

if E = 0 and T = 0 : listen in.

SG-DRL3 Option [A2]: Digit Replace - Default [00]

SG-DRL3-2L Option [1A2]/[2A2]: Digit Replace - Default [00]

This option works in with Option [77]/[177]/[277]. When Option [A2]/[1A2]/[2A2] is enabled, and Option [77]/[177]/[277] is programmed with an ASCII value, the receiver will replace or insert an account code digit. Option [A2]/[1A2]/[2A2] determines how to replace or insert a digit.

To replace a digit, set Option [A2]/[1A2]/[2A2] to 0x where x is the digit to be replaced.

To insert a digit, set Option [A2]/[1A2]/[2A2] to 8x where x is the digit in the account code, after which will be the inserted digit.

SG-DRL3 Option [A3]: D6500 RS-232 - Default [00]

SG-DRL3-2L Option [1A3]/[2A3]: D6500 RS-232 - Default [00]

This option is used to strip hex digits on the automation output. The line card will emulate the Radionics 6500 RS-232 protocol on pulse formats, Ademco Express and Varitech only. When Option [A3]/[1A3]/[2A3] is set to 01 the hex digit will be stripped for 1-digit reporting codes including Varitech 4/1.

Example 1: Code 1

Computer output: **104091sssssss022sAsss1**

Example 2: Code B

Computer output: **104091sssssss022sOssss**

If Option [A3] set to 02: the hex digit will be stripped for 2-digit reporting codes including Varitech 4/2.

Example 1: Code 21

Computer output: **104091sssssss022sAss21**

Example 2: Code B1

Computer output: **104091sssssss022sOssss1**

If Option [A3]/[1A3]/[2A3] set to 03: the hex digit will be stripped for 1 and 2-digit reporting codes including Varitech.

If Option [A3]/[1A3]/[2A3] set to 04: the hex digit will be stripped for BFSK.

NOTE: This option will only work if Option [A4]/[1A4]/[2A4] is set to 01.

Example 1: Code 21

Computer output: **604091sssssss022sAss21**

Example 2: Code B1

Computer output: **604091sssssss022sOssss1**

If Option [A3]/[1A3]/[2A3] is set to 05: the hex digit will be stripped for 1-digit reporting and BFSK.

If Option [A3]/[1A3]/[2A3] is set to 06: the hex digit will be stripped for 2-digit reporting and BFSK.

If Option [A3]/[1A3]/[2A3] set to 07: the hex digit will be stripped for 1-digit, 2-digit and BFSK.

If Option [A3]/[1A3]/[2A3] set to 0F: the hex digit will be stripped for 1-digit, 2-digit, BFSK and Ademco Express (4-1, 4-2).

NOTES: Option [70]/[170]/[270] must be left as an individual event code when enabling this option.

When performing any conversion (Such as Pulse to Ademco HS or BFSK to Ademco HS), this option will NOT take effect.

SG-DRL3 Option [A4]: BFSK RS-232 - Default [00]

SG-DRL3-2L Option [1A4]/[2A4]: BFSK RS-232 - Default [00]

This option will dictate how the BFSK format will be outputted to the automation. At default (set to 00) the output will be as Radionics 6500. When set to 01, the output will be as a 3/1 extended format, and when set to 02 the output will be Ademco High Speed. The account code used in these examples is 055.

Value	Function	Examples
00	BFSK format will be reported as Radionics 6500. The protocol identifier will be a 6.	Example 1: Code 21 Computer Output: 604091 055sAsss2 Example 2: Code B1 Computer Output: 604091 055sOssss1
01	BFSK will be reported as a standard 3/1 extended format. The protocol identifier will be a 1.	Example 1: Code 21 Computer Output: 104091 055sAss21 Example 2: Code B1 Computer Output: 104091 055sOssB1

02	BFSK will be reported as Ademco High Speed for none-alarm events. The protocol identifier will be an 8. A leading '0' will be added to the account code to make it 4 digits in length. For alarm events (excluding fire) the output will be 4-1/4-2 , with a protocol identifier of 1, A leading '0' will be added to the account code.	Example 1: Code 21 Computer Output: 804091 0055s155s5555s7 Computer Output: 804091 0055s1555s5555s2 Example 2: Code 41 Computer Output: 104091 0055 41 Example 2: Code B1 Computer Output: 104091 0055 41
----	---	---

SG-DRL3 Option [A5]: Sescoa Super Speed - Default [01]
SG-DRL3-2L Option [1A5]/[2A5]: Sescoa Super Speed - Default [01]

This option will determine how the line card decodes 7-digit pulse formats.

Setting	Sescoa Super Speed	4/2/ checksum	4/2/checksum failed double round kiss-off	Decode Sescoa like SG-DRL2A
00	disabled	enabled	enabled	NO
01	enabled	disabled	disabled	NO
02	enabled	disabled	disabled	YES
03	disabled	enabled	disabled	NO

For a list of detailed event messages for the SG-DRL2A/SG-DRL3 decoding of sescoa format please reference the communication format document.

SG-DRL3 Option [A6]: ITI Adjust - Default [00]
SG-DRL3-2L Option [1A6]/[2A6]: ITI Adjust - Default [00]

When set to 01, the ITI account codes will be converted to 4 digits by stripping the last digit off. For example, a panel account of 23459 will become account 2345. If the leading digit of the panel account is a 0 then it will be stripped and replaced with a space. For example, if 02349 is sent then the receiver will output 234 for the panel account.

SG-DRL3 Option [A7]: Silent Knight FSK2 RS-232 - Default [00]

The channel provides two possible outputs to the computer for Silent Knight FSK2 format. The operation of this option is explained below:

[A7] = 00 SKFSK disabled
[A7] = 01 SKFSK enabled for:
SKFSK1
ERRLsssssAAAAAYYssss[DC4]
SKFSK2 Protocol #2
CRRLsssssAAAAAYYZss[DC4]
[A7] = 02 SKFSK enabled for:
SKFSK1
ERRLsssssAAAAAYYssss[DC4]
SKFSK2 Protocol #2
FRRLsssssAAAAAYYZss[DC4]

SG-DRL3 Options [A8] - [AF]: Dial-out Number For 2-way Audio Transfer - Default [00]

SG-DRL3-2L Options [1A8]/[2A8] - [AF]: Dial-out Number For 2-way Audio Transfer - Default [00]

These 8 options are used to provide the dial-out number if the user wishes to transfer the call to another extension. Up to 16 digits may be programmed including any 'Feature Command' digits. The values in these options will be sent as DTMF tones on the phone line after the following sequence takes place:

1. The receiver has recognized the current call as a 2-way audio account and alarm code.
2. The calling control panel has finished sending its alarms and switched into 2-way audio mode.
3. The channel will perform a Hook Flash with the time value as programmed in Option [11] and then start to dial the digits programmed.

Options [A8]/[1A8]/[2A8] - [AF]/[1AF]/[2AF] must be programmed in the following manner: Digits 1-9 are programmed as the numbers 1-9. The digit 'A' must be programmed if a zero is needed anywhere in the dial string as the digit zero is used to indicate to the line card that there are no more digits to dial. If a '*' is needed, (e.g., *70, the transfer command in some PBX/PABX switches) program a 'B'. Similarly, if a '#' is needed, program a 'C'.

To get the line card to wait for 3 seconds in a dial string, program a 'D'.

DTMF Table

DTMF Digit Sent	DTMF Digit Received	DTMF Digit Sent	DTMF Digit Received
0	End of dialling string	0	End of dialling string
1	1	1	1
2	2	2	2
3	3	3	3
4	4	4	4
5	5	5	5
6	6	6	6
7	7	7	7
8	8	8	8
9	9	9	9
A	0	A	0
B	*	B	*
C	C	C	C
D	3 second pause	D	3 second pause
E	E	E	E
F	F	F	F

For example: to have the receiver transfer a 2-way audio call to Ext. 51386, with a 3 second pause between the transfer command and dialing, Options [A8]/[1A8]/[2A8] to [AF]/[1AF]/[2AF] would be programmed as the following:

A8 = B7 AC = 60
A9 = AD AD = 00
AA = 51 AE = 00
AB = 38 AF = 00

SG-DRL3 Option [B0]: CCITT Audio Format Enable bits - Default [00]
SG-DRL3-2L Option [1B0]/[2B0]: CCITT Audio Format Enable bits - Default [00]

NOTE: DMP is not supported by the SG-DRL3-2L.

This option is similar to option [7F]/[17F]/[27F]. It gives you the ability to enable and disable audio for the selected CCITT formats. A '1' in the formats bit position will enable the format for audio. A '0' in the formats bit position will disable audio for the format.

Bit 0 Robofon Format Bit 4 Not Used
Bit 1 VONK Format Bit 5 Outel format
Bit 2 Stratel Format Bit 6 Not used
Bit 3 CESA Format Bit 7 Not used

For example: If the user wants audio to work only for Robofon format, Option [B0]/[1B0]/[2B0] should be programmed as 11 HEX which enables bit 0 and bit 4.

SG-DRL3 Option [B1]: DMP Area BIN or DEC Option - Default [00]
SG-DRL3-2L Option [1B1]/[2B1]: DMP Area BIN or DEC Option - Default [00]

NOTE: DMP is not supported by the SG-DRL3-2L.

This option is similar to the DMP receiver.

00 = Area is sent to the automation in BINARY
01 = Area is sent to the automation in DECIMAL

The printer outputs remain unchanged.

Examples: Area is sent to the linecard as C0,

BINARY setting

Automation:
P01001 20999 L0480TIMAREA 1
P01001 20999 L0440TIMAREA 2
Printer:

00-01-001-20999--Close USR:04 AREA1 TIMAREA 1
00-01-001-20999--Close USR:04 AREA2 TIMAREA 2

DECIMAL setting

Automation:
P01001 20999 L0401TIMAREA 1
P01001 20999 L0402TIMAREA 2
Printer:

00-01-001-20999--Close USR:04 AREA1 TIMAREA 1
00-01-001-20999--Close USR:04 AREA2 TIMAREA 2

SG-DRL3 Option [B2]: DTMF Format Disable #1 - Default [00]

SG-DRL3-2L Option [1B2]/[2B2]: DTMF Format Disable #1 - Default [00]

This option is bit oriented and will disable the decoding of the following DTMF formats.

Bit enabled

- 0x01: 15 digits DTMF format
- 0x02: 13 digits DTMF format
- 0x03: 8 digits DTMF format
- 0x08: 22 digits DTMF format
- 0x10: 11 digits DTMF format
- 0x20: 12 digits DTMF format
- 0x40: 23 digits DTMF format
- 0x80: 14 digits DTMF format

SG-DRL3 Option [B3]: Reserved

SG-DRL3-2L Option [1B3]/[2B3]: Reserved

SG-DRL3 Option [B4]: 4/3 DTMF format type - Default [00]

SG-DRL3-2L Option [1B4]/[2B4]: 4/3 DTMF format type - Default [00]

When disabled this option will allow the receiver to receive 4/3 DTMF formats as Sur-Gard 4/3. When enabled the receiver will be able to receive 4/3 DTMF as a 4/2/Checksum format.

SG-DRL3 Option [B5]: FSK Format disable - Default [00]

SG-DRL3-2L Option [1B5]/[2B5]: FSK Format disable - Default [00]

This option is bit oriented and will disable the decoding of the following pulse formats:

Bit enabled

- 0x01: Varitech Disable
- 0x02: Silent Knight Disable
- 0x04: BFSK Disable
- 0x08: - 0x80: Not used

SG-DRL3 Option [B6]: 4-2 Conversion to Ademco High Speed - Default [00]

SG-DRL3-2L Option [1B6]/[2B6]: 4-2 Conversion to Ademco High Speed - Default [00]

When a 4-2 format message is received on the receiver, the computer and printer messages will normally be outputted in the standard 4-2 format (option [B6]/[1B6]/[2B6] set to 0). However, when this option is enabled (set to 01) the standard 4-2 opening and closing codes by users (B0 - BF and C0 - CF) will be translated to Ademco High Speed. Whenever a 4-2 code beginning with B is received an opening report is sent and whenever a 4-2 code beginning with a C is received a closing report is sent. The User Identifier will be set to match the zone identifier of the message.

The 4-2 format signal: ACCT XY

will be converted to the Ademco High Speed format signal:

If X is B (Opening) the signal will be: ACCT Y222 2222 2

If X is C (Closing) the signal will be: ACCT Y444 4444 4

Example:

If the 4-2 opening event is: 1234 B1

The translated Ademco High Speed is: 1234 1222 2222 2

If the 4-2 closing event is: 1234 CB

The translated Ademco High Speed is: 1234 B444 4444 4

The following table outlines all possible translation into Ademco High Speed for the transmission of the standard 4-2 opening and closing codes: (Please note that account number 1234 was used for example purposes).

4-2 Format Signal	Automation Output	Printer Output
1234 B1	101001 1234 1222 2222 2	01-001 1234 1222 2222 2
1234 B2	101001 1234 2222 2222 2	01-001 1234 2222 2222 2
1234 B3	101001 1234 3222 2222 2	01-001 1234 3222 2222 2
1234 B4	101001 1234 4222 2222 2	01-001 1234 4222 2222 2
1234 B5	101001 1234 5222 2222 2	01-001 1234 5222 2222 2
1234 B6	101001 1234 6222 2222 2	01-001 1234 6222 2222 2
1234 B7	101001 1234 7222 2222 2	01-001 1234 7222 2222 2
1234 B8	101001 1234 8222 2222 2	01-001 1234 8222 2222 2
1234 B9	101001 1234 9222 2222 2	01-001 1234 9222 2222 2
1234 BA	101001 1234 0222 2222 2	01-001 1234 0222 2222 2

1234 BB	101001 1234 B222 2222 2	01-001 1234 B222 2222 2
1234 BC	101001 1234 C222 2222 2	01-001 1234 C222 2222 2
1234 BD	101001 1234 D222 2222 2	01-001 1234 D222 2222 2
1234 BE	101001 1234 E222 2222 2	01-001 1234 E222 2222 2
1234 BF	101001 1234 F222 2222 2	01-001 1234 F222 2222 2
1234 C1	101001 1234 1444 4444 4	01-001 1234 1444 4444 4
1234 C2	101001 1234 2444 4444 4	01-001 1234 2444 4444 4
1234 C3	101001 1234 3444 4444 4	01-001 1234 3444 4444 4
1234 C4	101001 1234 4444 4444 4	01-001 1234 4444 4444 4
1234 C5	101001 1234 5444 4444 4	01-001 1234 5444 4444 4
1234 C6	101001 1234 6444 4444 4	01-001 1234 6444 4444 4
1234 C7	101001 1234 7444 4444 4	01-001 1234 7444 4444 4
1234 C8	101001 1234 8444 4444 4	01-001 1234 8444 4444 4
1234 C9	101001 1234 9444 4444 4	01-001 1234 9444 4444 4
1234 CA	101001 1234 0444 4444 4	01-001 1234 0444 4444 4
1234 CB	101001 1234 B444 4444 4	01-001 1234 B444 4444 4
1234 CC	101001 1234 C444 4444 4	01-001 1234 C444 4444 4
1234 CD	101001 1234 D444 4444 4	01-001 1234 D444 4444 4
1234 CE	101001 1234 E444 4444 4	01-001 1234 E444 4444 4
1234 CF	101001 1234 F444 4444 4	01-001 1234 F444 4444 4

SG-DRL3 Option [B7]: Reserved

SG-DRL3-2L Option [1B7]/[2B7]: Reserved

SG-DRL3 Option [B8]: DTMF Format Disable#2 - Default [00]

SG-DRL3-2L Option [1B8]/[2B8]: DTMF Format Disable#2 - Default [00]

This option is bit-oriented and will disable the decoding of the following DTMF formats:

Bit enabled

- 0x01: 9 digits DTMF format
- 0x02: Not Used
- 0x04: Not Used
- 0x08: Not Used
- 0x10: Not Used
- 0x20: Not Used
- 0x40: Not Used
- 0x80: Not Used

The programming of this option shall be displayed as individual options with a text label in the bit mask.

SG-DRL3 Option [B9]: Noise/Fax Detection - Default [00]

SG-DRL3-2L Option [1B9]/[2B9]: Noise/Fax Detection - Default [00]

This option will allow the receiver to perform line condition tests when the call is answered. There are two functions that are performed when a call is received: Noise Detection, and Fax Detection.

To enable Noise/Fax and Fax Tone detection set the following:

Option bit value	Setting
0000 0000	No noise or fax and tone detection
0000 0001	Noise/fax detection enabled
0000 0010	Fax tone detection enabled
0000 0011	Fax /noise and tone detection enabled

Noise/Fax Detection

This will occur during pre-init handshake duration (see Option [05]/[105]/[205]) to perform the Fax/Noise test on the line. The DSP will require at least 150ms to evaluate the line and determine if it is noisy or a fax transmission is occurring. Overall, one cycle of this will require at least 250ms duration. If the pre-init handshake has not expired, the line card will perform the test again if it did not detect a Fax or Noise report. If a fax or Noise report was detected the receiver will generate a communication fail fax or a communication fail noise message.

If Noise is detected the receiver will continue to proceed through its programmed handshakes and format detection. If no valid signal is received then the receiver will log the call as a Communication Fail - Noise detected. If a valid signal is received (for example a SIA event) the signal will be processed as normal and no fail log will be made.

Fax tone detection

This will occur in the common mode detection for formats. In this check, the line card is looking for the 1170 ON report from the DSP. Once in this check, the line starts a 600 ms timer to check for the 1170 OFF report. If it sees the OFF report a valid fax tone is detected. If the

line card does not detect any other formats after the last handshake, it will generate a communication fail fax message. To avoid conflicting with other formats the sync bit for SIA is checked. However, there is no way at the moment to distinguish from the modem II formats. At most the receiver will miss the first bytes of modem, but once it detects modem, the second round is properly received.

There are four types of Communication Fail messages that can be created:

- A message is generated if the line card receives an Invalid DNIS.
- If the line card cycles through all programmed handshakes and no data is received in response.

Two new communication fail messages have been added to the communication fail automation and printer logs. These messages will occur in the event that the following conditions occur.

- if a fax signal is detected
- if a Noise call is generated

Call could not be processed because of bad DNIS structure or no response by the panel	001002[#0000 NYC0101]	01-002-0000--COMMUNICATION FAIL
Call failed due to detection of fax device on the call *	001002[#0000 NYC0102]	01-002-0000--COMMUNICATION FAIL Fax
Call failed due to detection of voice on the call *	001002[#0000 NYC0103]	01-002-0000--COMMUNICATION FAIL Noise

* New Messages

SG-DRL3 Option [BA]: DMP User Length - Default [00]

SG-DRL3-2L Option [1BA]/[2BA]: DMP User Length - Default [00]

NOTE: DMP is not supported by the SG-DRL3-2L.

This option is for the variable length user and zone numbers. The first digit in the option represents the user number and the second digit represents the zone number. For example, if Option [BA]/[1BA]/[2BA] is set for 24 then the receiver will output a 2-digit user number and a 4-digit zone number. The default value is 00 for 2-digit user and 2-digit zone number.

NOTE: Option [BA]/[1BA]/[2BA] affects DMP Serial 1 format not DMP Serial 3.

SG-DRL3 Option [BB]: Sur-Gard DTMF 4/3 Format Output - Default [00]

SG-DRL3-2L Option [1BB]/[2BB]: Sur-Gard DTMF 4/3 Format Output - Default [00]

Each nibbles of this option controls how the 4/3 format computer output string is formatted. The first nibble allows for the user and group codes for openings and closings to be combined. When programmed as "1x", group arming/disarming signals will be combined with the user code into one signal which will be sent to the computer.

Example, the following information may be sent to the computer: (The printer output does not change.)

Printer:

1234-B01 CloseGrp
1234-416 Close
1234-C02 OpenGrp
1234-532 Open

Computer:

1234 C1 16 (instead of 1234 C 01 and 1234 C 16)
1234 O2 32 (instead of 1234 O 02 and 1234 O 32)

If a user code is not received after the group opening/closing, the message "1234 C1 FF" will be sent; "FF" indicates that a user code was not received.

The second nibble of this option controls the user/zone number conversion. The Sur-Gard 4/3 DTMF format is made up of a 4-digit account code, a 1-digit event code, and a 2-digit hexadecimal zone code or user number. However, some central station software packages use a common event code and require decimal user codes. This option allows the user codes to be converted from hexadecimal to decimal to meet the needs of the central station software. Program with one of the following:

- X0 Send the last two digits as user codes without conversion.
- X1 Convert the last 2-digit user codes to decimal as shown here:

User Code Received	User Code after Conversion
00 to 99	00 to 99
B0 to B9	100 to 109
C0 to C9	110 to 119
D0 to D9	120 to 129
E0 to E9	130 to 139
F0 to F9	140 to 149

Example, if 1234 4B1 is received, 1234 C 101 will be sent to the computer.

- X2 Send the last 3 digits as the zone codes with the 5th digit still used as the event code.

Example, if 1234 161 is received, 1234 A 161 will be sent to the computer. When individual event codes are used, if 1234 401 is received, 1234 C 01 will be transmitted to the computer. When common event codes are used, if 1234 401 is received, 1234 Z 401 will be transmitted to the computer, where Z is the common event code.

- X3 Send the last 3 digits as the zone codes and convert the user codes only to decimal.

NOTE: When the first nibble of the option is set to 1 the 3-digit user codes will be combined with the group number as follows:

Code received	Code sent to computer
1234B01	No transmission
12344B1	1234 C1 101

SG-DRL3 Options [BC] - [FF]: Reserved

SG-DRL3-2L Options [1BC]/[2BC] - [1FF]/[2FF]: Reserved

Section 6 - SG-DRL3-IP Programming

NOTE: SG-System III Console v2.20 (or higher) software is required for programming and communication with SG-DRL3-IP Receiver Modules.

6.1 Options: [00] - [47]

✓ Indicates Default

Option [00]: For future use

Options [01] - [04]: Receiver IP Address

This IP address identifies the SG-DRL3-IP on the IP network. Each node on the IP network must be assigned a unique IP address, which is made up of a network identifier and a host identifier. The SG-DRL3-IP can only use Static IPs, DHCP is not supported. These options specify 4 bytes of the receiver IP address, from the high byte to low byte with highest (byte 3) in section [01] and lowest (byte 0) in section [04] in hexadecimal.

Defaults: 01: C0, 02: A8, 03: 00, 04: 01
(Represents: 192.168.000.001)

Options [05] - [08]: Receiver Subnet Mask Address

A mask used to determine what subnet an IP address belongs to. The subnet is a portion of a network that shares a common address component. On TCP/IP networks, subnets are defined as all devices whose IP addresses have the same prefix. Dividing a network into subnets is useful for both security and performance reasons. These options specify 4 bytes of receiver subnet mask address, from the high byte to low byte with highest (byte 3) in section [05] and lowest (byte 0) in section [08] in hexadecimal.

Defaults: 05: FF, 06: FF, 07: 00, 08: 00
(Represents: 255.255.000.000)

Options [09] - [0C]: Receiver Gateway

This is the address of the Gateway through which the SG-DRL3-IP must communicate to reach the T-LINK transmitter. This address is applied to all T-LINK modules connected to the SG-DRL3-IP.

These options specify the 4 bytes of the receiver gateway, from high byte to low byte with the highest (byte 3) in section [09] and the lowest (byte 0) in section [0C].

Defaults: 09: 00, 0A: 00, 0B: 00, 0C: 00
(Represents: 000.000.000.000)

Options [0D] - [0E]: Alarm Port Number

Use this option to set the Alarm Port connection number for your receiver. While the default value will suffice in environments involving just one receiver, Option [0D][0E] can be used to differentiate receivers in a complex, multiple receiver environment. If this option is changed, IP communication modules connected to the SG-DRL3-IP must be programmed with the new receiver number. Communicators connected to the receiver will send their signals to this port.

Defaults: 0D: 0B, 0E: F5
(Represents: 3061)

Option [0F]: Receiver Number

The receiver number is used for sending signals to the central station software. Refer to the manuals for any central station automation software being used to determine if there are any special requirements for this number. Also, ensure that there are no duplicate receiver numbers used.

Default: 01

Option [10]: Line Card Number

The Line Card Number provides a virtual identification code for each SG-DRL3-IP module. Hexadecimal numbers "01" to "FE" can be programmed in Option [01] to identify line cards.

Default: 01

Option [11]: Line Card Number Length

This option is used to determine how many digits from the line card number will be sent to the output. You also have the option of displaying the number in hex or decimal. Program this option with one of the following:

- 01 Sends only one hex digit to the printer or computer output (if you have a 2-digit line card number only the last digit will be sent to the output).
- 02 Sends 2 hex digit line card number to the output.
- 03 Send 3 hex digit line card number to the output (leading zeros will be inserted prior to the line card number).
- ✓ 0A Send 3-digit line card number in decimal; send 2-digit receiver number in decimal
- 0D Send 3-digit line card number in decimal

Option [12]: Debug Output

The debug mode should only be used when required and disabled after use. Enabling the Debug option reduces the SG-DRL3-IP receiver's ability to monitor the T-LINK transmitters.

- ✓ 00 Disabled

Options [13] - [14]: Transmitter Absent Debounce Time

The time, in seconds, for which a transmitter configured in supervised mode must be absent before a transmitter failure condition will be reported. Valid entries are 30-65535 seconds. Value entered in hex.

Default: 078 (120s)

NOTE: Transmitter Absent Time should not be less than 90 seconds. For ULC Installations Security Level 4, this option shall be programmed as 5A (90s), 4B (75s) for Security Level 5. For UL Installations, this option shall be programmed as B4 (180s).

For UL Listed products, the permitted setting is 05AH(90s).

Options [15] - [16]: Transmitter Restoral Time

This option determines the required time a transmitter must be present before it is registered in the Account Table and the transmitter restoral message is sent.

Transmitter Restore Time must be 30 seconds minimum.

Default: 003C (60s)

For UL Listed products, the permitted setting is 05AH(90s).

Option [19]: Transmitter Restoral Trouble Mask

This programmable mask enables or disables the reporting of the Transmitter restoral condition on the SG-DRL3-IP receiver. Setting the mask to 0 signifies the trouble will be reported; setting the mask to 1 signifies the trouble will not be reported.

- ✓ 00 Condition reported
- 01 Condition not reported (masked)

For UL Listed products, the permitted setting is OFF.

Option [1A]: Transmitter Failure Trouble Mask

This programmable mask enables or disables the reporting of the Transmitter failure/absent condition on the SG-DRL3-IP receiver. Setting the mask to 0 signifies the trouble will be reported; setting the mask to 1 signifies the trouble will not be reported.

- ✓ 00 Condition reported
- 01 Condition not reported (masked)

For UL Listed products, the permitted setting is OFF.

Option [1B]: Transmitter Swap Trouble Mask

This programmable mask enables or disables the reporting of the T-LINK transmitter swap condition on the SG-DRL3-IP receiver. Setting the mask to 0 signifies the trouble will be reported; setting the mask to 1 signifies the trouble will not be reported.

- ✓ 00 Condition reported
- 01 Condition not reported (masked)

For UL Listed products, the permitted setting is OFF.

Option [1C]: Transmitter Unencrypted Trouble Mask

This programmable mask enables or disables the reporting of the T-LINK transmitter sending an unencrypted event when the SG-DRL3-IP is expecting an encrypted event condition on the SG-DRL3-IP receiver. Setting the mask to 0 signifies the trouble will be reported; setting the mask to 1 signifies the trouble will not be reported.

- ✓ 00 Condition reported
- 01 Condition not reported (masked)

For UL Listed products, the permitted setting is OFF.

Option [1D]: Invalid Report Trouble Mask

This programmable mask enables or disables the reporting the invalid report condition. SG-DRL3-IP determines that the signal received is invalid, bad checksum, encryption key miss-match. Setting the mask to 0 signifies the trouble will be reported; setting the mask to 1 signifies the trouble will not be reported.

- ✓ 00 Condition reported
01 Condition not reported (masked)

For UL Listed products, the permitted setting is OFF.

Option [1E]: Unknown Account Trouble Mask

This programmable mask enables or disables the reporting an unknown account report condition when the SG-DRL3-IP received is from an invalid account (not in the account table). Setting the mask to 0 signifies the trouble will be reported; setting the mask to 1 signifies the trouble will not be reported.

- ✓ 00 Condition reported
01 Condition not reported (masked)

For UL Listed products, the permitted setting is OFF.

Option [1F]: Accounts Exceeded Trouble Mask

This programmable mask enables or disables the reporting if the account table limit is exceeded when a new account tries to connect to a SG-DRL3-IP that has a full account table. Setting the mask to 0 signifies the trouble will be reported; setting the mask to 1 signifies the trouble will not be reported

- ✓ 00 Condition reported
01 Condition not reported (masked)

For UL Listed products, the permitted setting is OFF.

Option [20]: Transmitter Deleted Trouble Mask

This programmable mask enables or disables the reporting when a T-LINK transmitter account deleted from the table. Setting the mask to 0 signifies the trouble will be reported; setting the mask to 1 signifies the trouble will not be reported.

- ✓ 00 Condition reported
01 Condition not reported (masked)

Option [2A]: For Future Use

Option [2B]: Busy Out

The line card will stop acknowledging transmitter events under specific trouble conditions if Option [27] is programmed with the following:

- ✓ 00 No time set from SG-CPM3, a code corruption checksum error, or an internal buffer is in full condition
01 Line card is being downloaded
04 No time set from SG-CPM3, a code corruption checksum error, line card is being downloaded, if internal buffer is full, or loss of communication with the SG-CPM3
05 No time set from the SG-CPM3, automation computer is absent, loss of SG-CPM3, line card is being downloaded

NOTE: If this 01 is selected, the line card will overwrite the oldest alarm with a new alarm when the internal buffer is full.

For UL Listed products, the permitted setting is 00.

Option [2C]: Internal Messages RS-232

When this option is programmed as '00', the SG-DRL3-IP will output its internal messages in the following format:

SRLLLL[#AAAA|Nxyy]

If it is programmed as '01' internal messages will be output as:

ORLLLL[#AAAA|Nxyy]

- S, 0 (zero) = Protocol number
RR = Receiver number
LLL = Line number
AAAA = Account code, always 0000
00 = Output for all internal signals is SRRL protocol
✓ 01 = Output for all internal signals is ORRL protocol
02 = Output signals in automation protocol SRRL with leading space in the zone (DVACS only)
03 = Output signals in automation protocol ORRL with leading space in the zone (DVACS only)

Options [2D] to [39]: For Future Use

Options [3A]-[3B] Console Port

These options set the 2 byte Console Connection Port Number with high byte in section [3A] and low byte in section [3B]. If this option is changed, the console connected to the SG-DRL3-IP must be programmed with the new port number.

Defaults: 3A: 0B, 3B: F8
(Represents: 3064)

Options [40] - [43] Console Password

This is the password for the Account Port communication. In order for the user to be able to retrieve/modify the account table of the receiver the application must have a password that matches this section. Applications that connect to this port are:

- T-Link Console
SG-Receiver Consoles
Table Loader
DLS (downloading software)
Default: 40:0C 41:0A 42:0F 43:0E
(Represents: CAFE)

Options [44]: DNIS Replacement of RRLLL

When set to 00 the SG-DRL3-IP will output the RRLLL (Receiver number and line number)

When set to 01 the SG-DRL3-IP will output the DNIS received from a GS transmitter instead of the RRLLL

Default: [00]

Option [46]: Account Digit Stripping

The option controls the output of the account number set from 1 to 9 digits for both T-Link transmitter and panel account code. If the option is set to '00' T-Link transmitter account code will be sent to the output as 10 digits and panel account code will be sent as received.

For example if Option [46] is set to '0x07' the following will occur:

Table with 2 columns: Transmitter, Output. Rows: 1234567890, 0000001234, 0012345678

Table with 2 columns: Panel, Output. Rows: 567890, 7890, 00567890

If the option [46] is set to '00' the following will occur:

Table with 2 columns: Transmitter, Output. Rows: 1234567890, 0000001234

Table with 2 columns: Panel, Output. Rows: 567890, 7890, 00567890

Default: [00]

Option [47]: SIM Number Output

This option is available with the GS transmitter. When enabled, the receiver will output the received SIM number to the printer and automation. The message will include the account number (up to 10 digits following Option [46]) and the SIM number (21 digits). The automation software used with the receiver will need to support the (s) protocol via the Sur-Gard output format in order for this feature to work.

Available settings for SIM Number output:

- 00 – Disabled – No SIM Number output
01 – SIM Number output to printer and automation
02 – SIM Number output to printer only
03 – SIM Number output to automation only

The automation output is as follows:

sRLLLLAAAAAAAAAASSSSSSSSSSSSSSSSSSSSSSSS

Where:

S is the protocol identifier
RRLLL is the Receiver and Line number of the line card that received the event

A is the 10-digit account number

S is the SIM number of the transmitter that sent the event

Default: [00]

Glossary

Account	The portion of a signal which contains the information identifying the location or the owner of the alarm panel. Also referred to as account number, account code or account digits.
Acknowledgement (ACK)	A signal sent from the receiver to the panel indicating that data has been received. A positive acknowledgement (ACK) means data was received without any detected errors. (see kiss-off). A negative acknowledgement (NAK) means data was received, but there were detected errors. An acknowledgement may be sent per packet or per alarm.
AHS	Automatic Handshake Selection. Refers to the receiver feature which enables the line card to request the handshake to be used with a particular panel from the CPM. The CPM maintains a database of most recently used handshakes for all accounts connected to the receiver. Handshakes are stored along with the phone number of the associated alarm panel.
Alarm	A message transmitted from the panel to the receiver containing account, event, zone, user or other information. There may be one or more per call. An alarm may be repeated in the same call (if not successfully delivered in a previous attempt). An alarm will contain one or more packets. Packets can contain rounds or different information. Alarm transmission is initiated with a handshake and, if received correctly, acknowledged with a kiss-off.
ANI	Automatic Number Identification.
ASCII	America Standard Code for Informational Interchange. A seven-bit alphanumeric code used extensively in data communications. Parity is often added to the seven-bit code for error detection.
Automation	The combination of software package and PC which connects to the receiver to receive alarm events. The automation can be connected either by direct serial connection or TCP.
Automation Message	The alarm information delivered by a receiver in a specified protocol to a central station computer or network. Also referred to as a computer message
Backplane	See SG-BP3X.
Block	A group of data that specifically makes up one of the elements of an alarm. For example: account block, event block, or alarm block. One packet could contain multiple blocks.
Busy Out	A state of a line card. Under predefined criteria the line card will go off-hook so as to not process any new alarms.
Call	The process of a receiver going off-hook, receiving one or more alarms and returning on-hook.
Caller ID	An FSK format received by the line card. This format can be received prior to sending the handshakes. The Caller ID data can be used by the receiver to provide additional information to all alarms received during a call.
Capture	The ability of a receiver to store commands sent to the panel from the automation computer after all of the alarms have been sent from the panel to the receiver.
Centronics	A parallel printer interface standard. Also known as standard IEEE1284. A centronics interface is implemented on the SG-CPM3 (through the backplane) to interface to the local parallel printer.
Checksum	Additional data added to an alarm indicating whether the contents have been received correctly. This is generally done by summing all the digits in the message (mod 256) and reporting this as the checksum. Different methods of calculating a checksum may be specified in particular formats or protocols.
C.L.A.S.S	Custom Local Area Signaling Services. This term is used in the telephone industry to represent all features of a telephone line, such as Caller-ID, Call Forwarding, 3-Way Calling etc.
Client	One side of a 2-sided TCP socket connection. The client is the one responsible for initiating the socket connection with the remote host (the server). The console represents the client side of the socket connection with the SG-CPM3.
Computer Message	See Automation Message.
Console	A PC application program which can connect to the receiver and provide diagnostic/programming abilities to the user. For the SG-System III, the console connects to the SG-CPM3 via TCP/IP.
Dialer	Another name for a control panel.
DNIS	Dialed Number Identification Service.
DTMF	Dual Tone Multiple Frequency. A method of dialing which utilizes 2 sets of 4 tones (frequencies) each. Selecting one tone from each set will produce 16 distinct pairs. These pairs are used to dial digits when dialing a telephone number.
Ethernet	A network protocol which encompasses the lowest logical layer of the network stack, immediately above the physical layer. This protocol is governed by the IEEE and is outlined in the IEEE802.3 specification. Ethernet consists of several variations, including 10Base2, 10Base5, 10BaseT, 100BaseT, and others. 10BaseT and 100BaseT are the most prevalent.
Equivalent Line Number	An option in the receiver. By default printer and computer messages will contain the line card number. Sometimes it is necessary to output the printer and computer messages with a different line card number; in this case this option can be used to overwrite the line card number in the printer and computer outputs of the receiver.
Event	The specific type of alarm being reported by the panel.
Event Code	A term used to describe a character or group of characters in an automation output. This character(s) is used to represent the event that was reported by the panel. Example 1: Sur-Gard automation reports an alarm event using an event code of 'A', Restore as 'R', or Trouble as 'T'. Example 2: Sur-Gard automation reports using a SIA output for a burglary alarm using an event code of 'BA'.
FES	Format Expert Systems. The name given to a receiver task which performs the basic functions of: 1. sending handshakes; 2. detecting the format from the panel; 3. processing the alarm from the panel; 4. sending a kiss-off to the panel.
Format	The pre-established order of events and meanings of the various characters in an alarm transmitted from a panel to a receiver.
FSK	Frequency Shift Keying. A modulation technique used with low-speed modems (300 to 1800 bps). The carrier frequency is shifted between two discrete frequencies in accordance with the binary serial data.
Handshake	A signal sent by the receiver to a panel indicating that a connection has been established. These are either tones or modem data.
Heartbeat	A periodic signal sent from the automation outputter tasks to the automation software to verify the presence of that output. The period of this heartbeat is controlled via an option in the SG-CPM3. Alternatively, the heartbeat refers to the signal sent between SG-CPM3s to verify the presence/absence of each other.
Hook Flash	The process of the receiver going temporarily off-hook, usually in an attempt to transfer the phone call.

Hot-Swappable	Refers to the ability to add or remove particular cards to or from the system without removing power. In the SG-System III, the SG-CPM3, SG-DRL3, SG-DC/DC3 and SG-PSC3 are all fully hot-swappable.
HTTP	Hypertext Transfer Protocol. A higher level protocol within the TCP/IP suite of protocols which is responsible for implementing web browsers. This is the protocol implemented by the SG-CPM3 to enable the web interface to function.
IEEE 1284	See Centronics.
IEEE 802.3	See Ethernet.
Inter-burst Time	A term for the reception of pulse formats. The time between two bursts.
Inter-digit Time	A term used for reception of pulse or DTMF formats. The time between two digits.
Internal Trouble	A trouble condition which is generated inside a receiver, as opposed to being sent as an alarm from the panel. Internal troubles are also sent to the printer and automation outputs.
Kiss-off	A term used in the security industry for a positive acknowledgement.
Line	An individual channel on a line card. Equivalent to 1 telephone line.
Line Card	A removable, hot-swappable card which contains a POTS line interface which controls 1 or more POTS lines. For SG-System III, each line card (SG-DRL3) will interface to 1 line.
Line Conditioning	Electrical compensation for attenuation and phase delay distortion exhibited by the PSTN. Conditioning is performed through the use of an equalizer.
MAC Address	Media Access Control. A globally unique device 6-byte address which identifies a device attached to an Ethernet network. Assignment of MAC addresses is governed by the IEEE; any OEM company which manufactures Ethernet devices must apply for and purchase an OUI (Organizationally Unique Identifier), which consists of a block of 16,777,216 MAC addresses, all of which have the same first 3 bytes. Subsequent allocation of addresses within that block is at the discretion of the purchaser. Each Ethernet device produced must be programmed with a different MAC address in order to guarantee that each device will function correctly on the network. For the SG-System III, the MAC address is stored in serial EEPROM on the SG-CPM3 board. It is only programmable during manufacturing.
MPC860	The Power PC microprocessor used as the main processor on the SG-CPM3 board.
Multidrop	A communication link in which a single channel is shared by several stations or nodes (DVACS is a Multidrop network). Only one station may transmit at a time. Multidrop is also referred to as multipoint.
Negative Acknowledgement (NAK)	See acknowledgement.
Off-Hook	The process of connecting to the telephone line to answer an incoming call or dial a remote device (answering).
On-Hook	The process of releasing the telephone line after completion of a call (hanging up).
Options	A set of user-configurable parameters which controls the operation of a device. In the SG-System III, both the SG-DRL3 and the SG-CPM3 contain sets of options. Static options affect all Profiles on a card. Dynamic options are unique to each profile.
Packet	A group of digits or characters of information in an alarm.
Panel	A device (the alarm system) at the protected premises used to transmit alarms to the receiver.
Ping	A standard network command which can be used to verify the presence of a device on a network, using the device IP address. Ping is implemented as part of the ICMP protocol and consists of the Echo Request and Echo Reply commands (poll and response respectively).
POTS	Plain Old Telephone System. An acronym used to describe a standard analog telephone network, or alternatively a standard analog telephone line.
Printer Message	The alarm information delivered by a receiver to a central station printer. This information is generally encapsulated in a descriptive English text message.
Profile	Generally refers to a group of options. The receiver can select a "profile" based on certain conditions.
Protocol	The pre-established order of events and meanings of the various characters in the information transmitted from a receiver to a monitoring computer.
PSTN	Public Switched Telephone Network. Analogous to POTS.
Receiver	The equipment used to receive alarms sent from panels. Sur-Gard's receivers are the SLR and the MLR. 'Receiver' is sometimes used interchangeably with 'line card' as it is the line card which actually receives the alarm in the MLR.
Ring	One of the wires used on a phone line. By convention this is red.
Rounds	Two or more packets of alarm information used for error checking. If two packets (rounds) are identical the packet contains valid data.
RRLLL	The part of the automation message which stores the receiver number and line card number. The length of this field is variable and is controlled via an option in both the line card and the SG-CPM3.
RS-232	An asynchronous, point-to-point serial communications protocol. Used to communicate between the SG-DRL3 and a PC for the SG-DRL3's debug output. Also used to communicate between the SG-CPM3 and the automation computer, and the SG-CPM3 and a PC for the SG-CPM3's debug output.
Server	One side of a 2-sided TCP socket connection. The server is the one responsible for receiving the socket connection with the remote host (the client). In general, a host which acts as a server can receive multiple client socket connection requests simultaneously. The SG-CPM3 acts as a server to both the console and the web interface.
SG	Sur-Gard, a brand name of DSC. Also used to describe a particular type of automation output.
SG-BP3X	A motherboard-style PCB which acts as the backbone for a single shelf of a SG-System III receiver. The SG-BP3X contains sockets to which up to 12 SG-DRL3s, 1 SG-CPM3, 1 SG-PSC3 and 2 SG-DC/DC3s can be connected. Furthermore, 2 SG-BP3Xs can be connected together to form a 2-shelf configuration for the SG-System III receiver. The SG-BP3X also contains connections for a parallel printer and 2 serial automation COM ports, as well as an Ethernet connection. Also referred to as a backplane.
SG-CPM3	Central Processing Module 3. The SG-CPM3 controls the overall operation of the SG-System III receiver, which includes multiplexing alarm signals from the line cards and sending them to the appropriate outputs.

SG-DC/DC3	The DC power supply of the SG-System III receiver.
SG-DRL3	Digital Receiver Line Card 3.
SG-DRL3-2L	Dual Line Digital Receiver Line Card 3.
SG-MLRF3	The metal rack which is used to enclose all other modules within a single shelf of the SG-System III receiver.
SG-PSC3	Power Supply Controller 3.
SG-PSU3	Power Supply Unit 3.
SG-System III	Name given to a single entire receiver configuration, including rack, SG-CPM3(s), line card(s), power supply, etc.
SG-UIB3	User Interface Board 3. An L-shaped board which connects to the SG-CPM3 and contains output LEDs and 4 push buttons used for the user interface. This board also connects directly to the LCD screen.
SIA	Security Industry Association. Sometimes referred to as the SIA format which is an example of FSK modulation.
TCP/IP	Transmission Control Protocol/Internet Protocol. A standard network communications protocol. On the SG-System III, TCP/IP is used to communicate between the console and the SG-CPM3. It is also used to connect the SG-CPM3 to a TCP printer (resident on the console) and TCP automation software (runs independent of the console).
Tip	One of the wires used on a phone line. By convention this is green.
Zone	The portion of an alarm which contains the information identifying the specific zone of the panel that has been violated.

Appendix A - Printer Words: Options [60-6F]

Hex #	Printer Words
00	MEDICAL*
01	PENDANT TRANSMITTER
02	FAIL TO REPORT IN
03	RESERVED
04	RESERVED
05	RESERVED
06	RESERVED
07	RESERVED
08	RESERVED
09	RESERVED
0A	FIRE ALARM
0B	SMOKE
0C	COMBUSTION
0D	WATER FLOW
0E	HEAT
0F	PULL STATION
10	DUCT
11	FLAME
12	NEAR FIRE ALARM
13	RESERVED
14	PANIC ALARM
15	DURESS ALARM
16	SILENT ALARM
17	AUDIBLE ALARM
18	DURESS
19	DURESS
1A	RESERVED
1B	RESERVED
1C	RESERVED
1D	RESERVED
1E	BURGLARY
1F	PERIMETER
20	INTERIOR
21	24 HOUR
22	ENTRY/EXIT
23	DAY/NIGHT
24	OUTDOOR
25	TAMPER
26	NEAR BURGLARY ALARM
27	INTRUSION VERIFIER
28	GENERAL ALARM
29	POLLING LOOP OPEN
2A	POLLING LOOP SHORT
2B	EXPANSION MODULE FAILURE
2C	SENSOR TAMPER
2D	EXPANSION MODULE TAMPER
2E	SILENT BURG
2F	SENSOR SUPERVISION FAILURE
30	RESERVED
31	RESERVED
32	24 HOUR NON-BURGLARY
33	GAS DETECTED*
34	REFRIGERATION*
35	LOSS OF HEAT*
36	WATER LEAKAGE*
37	FOIL BREAK*
38	DAY TROUBLE
39	LOW BOTTLED GAS LEVEL *
3A	HIGH TEMPERATURE*
3B	LOW TEMPERATURE*
3C	RESERVED
3D	LOSS OF AIR FLOW*

* Use only with Model SG-System III CE.
 SG-System III CE is not UL Listed.

Hex #	Printer Words
3E	CARBON MONOXIDE*
3F	TANK LEVEL*
40	RESERVED
41	RESERVED
42	RESERVED
43	RESERVED
44	RESERVED
45	RESERVED
46	FIRE SUPERVISORY
47	LOW WATER PRESSURE*
48	LOW CO2*
49	GATE VALVE SENSOR*
4A	LOW WATER LEVEL*
4B	PUMP ACTIVATED*
4C	PUMP FAILURE*
4D	RESERVED
4E	RESERVED
4F	RESERVED
50	SYSTEM TROUBLE
51	AC LOSS
52	LOW SYSTEM BATTERY
53	RAM CHECKSUM BAD
54	ROM CHECKSUM BAD
55	SYSTEM RESET
56	PANEL PROGRAM CHANGED
57	SELF-TEST FAILURE
58	SYSTEM SHUTDOWN
59	BATTERY TEST FAILURE
5A	GROUND FAULT
5B	BATTERY MISSING/DEAD
5C	POWER SUPPLY OVERCURRENT
5D	ENGINEER RESET
5E	RESERVED
5F	RESERVED
60	RESERVED
61	RESTORE ALARM
62	OPENING ALARM
63	CLOSING ALARM
64	SOUNDER/RELAY
65	BELL 1
66	BELL 2
67	ALARM RELAY
68	TROUBLE RELAY
69	REVERSING
6A	NOTIFICATION APPLIANCE 3 CHECK
6B	NOTIFICATION APPLIANCE 4 CHECK
6C	RESERVED
6D	RESERVED
6E	SYSTEM PERIPHERAL
6F	POLLING LOOP OPEN
70	POLLING LOOP SHORT
71	EXPANSION MODULE FAILURE
72	REPEATER FAILURE
73	LOCAL PRINTER PAPER OUT
74	LOCAL PRINTER FAILURE
75	EXPANSION MODULE DC LOSS
76	EXPANSION MODULE LOW BATTERY
77	EXPANSION MODULE RESET
78	RESERVED
79	EXP. MODULE TAMPER
7A	EXP. MODULE AC LOSS
7B	EXP. MODULE SELF-TEST FAIL

Hex #	Printer Words
7C	LOSS SUPERVISORY RF
7D	RESERVED
7E	RESERVED
7F	RESERVED
80	RESERVED
81	RESERVED
82	COMMUNICATION
83	TELCO 1 FAULT
84	TELCO 2 FAULT
85	LONG RANGE RADIO
86	FAIL TO COMMUNICATE
87	LOSS OF RADIO SUPERVISION
88	LOSS OF CENTRAL POLLING
89	VSWR
8A	RESERVED
8B	RESERVED
8C	PROTECTION LOOP
8D	PROTECTION LOOP OPEN
8E	PROTECTION LOOP SHORT
8F	FIRE TROUBLE
90	EXIT ALARM
91	PANIC ZONE TROUBLE
92	HOLDUP ZN TROUBLE
93	SWINGER TROUBLE
94	CROSS ZONE TROUBLE
95	RESERVED
96	SENSOR TROUBLE
97	LOSS OF SUPERVISORY - RF
98	LOSS OF SUPERVISORY - RPM
99	SENSOR TAMPER
9A	RF TRANSMITTER. LOW BATTERY
9B	SMOKE HI-SENSOR
9C	SMOKE LOW-SENSOR
9D	INTRUSION HI-SENSOR
9E	INTRUSION LOW-SENSOR
9F	SELF TEST FAIL
A0	OPEN/CLOSE
A1	O/C BY USER
A2	GROUP O/C
A3	AUTOMATIC O/C
A4	LATE O/C
A5	DEFERRED O/C
A6	CANCEL
A7	REMOTE ARM/DISARM
A8	QUICK ARM
A9	KEYSWITCH O/C
AA	RESERVED
AB	CALLBACK REQUEST MADE
AC	SUCCESSFUL DOWNLOAD ACCESS
AD	UNSUCCESSFUL ACCESS
AE	SYSTEM SHUTDOWN
AF	DIALER SHUTDOWN
B0	SUCCESS FULL UPLOAD
B1	RESERVED
B2	RESERVED
B3	RESERVED
B4	RESERVED
B5	ACCESS DENIED
B6	ACCESS REPORT BY USER
B7	FORCED ACCESS
B8	EGRESS DENIED
B9	EGRESS GRANTED
BA	ACCESS
BB	ACCESS
BC	ACCESS
BD	ACCESS

Hex #	Printer Words
BE	RESERVED
BF	ARMED STAY
C0	KEYSWITCH ARMED STAY
C1	RESERVED
C2	RESERVED
C3	RESERVED
C4	RESERVED
C5	RESERVED
C6	GROUP CLOSING
C7	GROUP OPENING
C8	EXCEPTION O/C
C9	EARLY O/C
CA	LATE O/C
CB	FAIL TO O/C
CC	FAIL TO O/C
CD	AUTO ARM FAIL
CE	O/C PARTIAL ARMED
CF	EXIT ERROR
D0	USER PRESENT
D1	RECENT CLOSE
D2	SOUNDER/RELAY DISABLED
D3	BELL 1 DISABLE
D4	BELL 2 DISABLE
D5	ALARM RELAY DISABLE
D6	TROUBLE RELAY DISABLE
D7	REVERSING RELAY DISABLE
D8	NOTIFICATION APPLIANCE 3 DISABLED
D9	NOTIFICATION APPLIANCE 4 DISABLED
DA	RESERVED
DB	RESERVED
DC	RESERVED
DD	DIALER DISABLED
DE	RADIO TRANSMITTER DISABLED
DF	REMOTE UPLOAD/DOWNLOAD DISABLED
E0	RESERVED
E1	RESERVED
E2	RESERVED
E3	RESERVED
E4	MESSAGE
E5	SERVICE
E6	ZONE BYPASS
E7	FIRE BYPASS
E8	24 HOUR ZONE BYPASS
E9	BURGLARY BYPASS
EA	GROUP BYPASS
EB	SWINGER BYPASS
EC	ACCESS ZN SHUNT
ED	ACCESS POINT BYPASS
EE	RESERVED
EF	UNBYPASS
F0	RESERVED
F1	MANUAL TRIGGER TEST
F2	PERIODIC TEST REPORT
F3	PERIODIC RF TRANSMISSION
F4	FIRE TEST
F5	STATUS REPORT TO FOLLOW
F6	LISTEN-IN TO FOLLOW
F7	WALK TEST MODE
F8	OFF NORMAL CONDITION
F9	VIDEO TRANSMITTER ACTIVE
FA	RESERVED
FB	FIRE POINT TEST
FC	FIRE POINT NOT TESTED
FD	INTRUSION ZONE WALK TESTED
FE	FIRE ZONE WALK TESTED
FF	PANIC ZONE WALK TESTED

Appendix B - TELCO Connector Pin-outs

NOTES:

All B channels are used for 2-way audio or backup telephone line for the SG-DRL3.
For the SG-DRL3-2L all B channels are the second phone line input for the line card.

Pins 25,50 - Not used

Pin		Port
1	26	A Tip/Ring Channel 1
2	27	B Tip/Ring Channel 1
3	28	A Tip/Ring Channel 2
4	29	B Tip/Ring Channel 2
5	30	A Tip/Ring Channel 3
6	31	B Tip/Ring Channel 3
7	32	A Tip/Ring Channel 4
8	33	B Tip/Ring Channel 4

Pin		Port
9	34	A Tip/Ring Channel 5
10	35	B Tip/Ring Channel 5
11	36	A Tip/Ring Channel 6
12	37	B Tip/Ring Channel 6
13	38	A Tip/Ring Channel 7
14	39	B Tip/Ring Channel 7
15	40	A Tip/Ring Channel 8
16	41	B Tip/Ring Channel 8

Pin		Port
17	42	A Tip/Ring Channel 9
18	43	B Tip/Ring Channel 9
19	44	A Tip/Ring Channel 10
20	45	B Tip/Ring Channel 10
21	46	A Tip/Ring Channel 11
22	47	B Tip/Ring Channel 11
23	48	A Tip/Ring Channel 12
24	49	B Tip/Ring Channel 12

NOTE: On the SG-BPX3 the B ports are the channels used for 2-way audio or back-up telephone line; Refer to SG-DRL-3 options for further information.

Appendix C - DEC-HEX-BIN Conversion Chart

Dec	Hex	Binary	Dec	Hex	Binary
000	00	0000 0000	027	1B	0001 1011
001	01	0000 0001	028	1C	0001 1100
002	02	0000 0010	029	1D	0001 1101
003	03	0000 0011	030	1E	0001 1110
004	04	0000 0100	031	1F	0001 1111
005	05	0000 0101	032	20	0010 0000
006	06	0000 0110	033	21	0010 0001
007	07	0000 0111	034	22	0010 0010
008	08	0000 1000	035	23	0010 0011
009	09	0000 1001	036	24	0010 0100
010	0A	0000 1010	037	25	0010 0101
011	0B	0000 1011	038	26	0010 0110
012	0C	0000 1100	039	27	0010 0111
013	0D	0000 1101	040	28	0010 1000
014	0E	0000 1110	041	29	0010 1001
015	0F	0000 1111	042	2A	0001 1010
016	10	0001 0000	043	2B	0010 1011
017	11	0001 0001	044	2C	0010 1100
018	12	0001 0010	045	2D	0010 1101
019	13	0001 0011	046	2E	0010 1110
020	14	0001 0100	047	2F	0010 1111
021	15	0001 0101	048	30	0011 0000
022	16	0001 0110	049	31	0011 0001
023	17	0001 0111	050	32	0011 0010
024	18	0001 1000	051	33	0011 0011
025	19	0001 1001	052	34	0011 0100
026	1A	0001 1010	053	35	0011 0101

Appendix D - ASCII Character Chart

Corresponding ASCII on printer (Option 70) Hex Character

Code	Character	Code	Character
20	Space	49	I
30	0	4A	J
31	1	4B	K
32	2	4C	L
33	3	4D	M
34	4	4E	N
35	5	4F	O
36	6	50	P
37	7	51	Q
38	8	52	R
39	9	53	S
41	A	54	T
42	B	55	U
43	C	56	V
44	D	57	W
45	E	58	X
46	F	59	Y
47	G	5A	Z
48	H	5C	\

Appendix E - SG-DRL3 Communication Formats

Name	Handshake	Data	Baud	Format	Extended	Kiss Off
Acron *	1400/2300Hz	DTMF	DTMF	3/8, 4/8	NO	1400/2300Hz
Ademco Express	Dual Tone	DTMF	DTMF	4/1(option), 4/2	NO	1400Hz
Ademco Slow	1400Hz	1900Hz	10bps	3/1,4/1(or 3/2),4/2	NO	1400Hz
Ademco Slow	1400Hz	1900Hz	10bps	4/2,4/1,3/1	YES	1400Hz
Contact ID	Dual Tone	DTMF	DTMF	4/2/1/3/2/3	NO	1400Hz
Contact ID 10 Digit	Dual Tone	DTMF	DTMF	10/2/1/3/2	NO	1400Hz
FBI Super Fast	2300Hz	DTMF	DTMF	4/3/1	NO	2300Hz
Franklin	2300Hz	1800Hz	20bps	3/1,4/1(or 3/2), 4/2	NO	2300Hz
Franklin	2300Hz	1800Hz	20bps	4/2,4/1,3/1	YES	2300Hz
ITI	ITI	FSK	110/300 Baud	-	NO	ITI
Modem II	Modem II	FSK	110 Baud	FSK	NO	Modem II
Modem IIE	Modem II	FSK	300 Baud	-	NO	Modem IIE
Modem IIIa ²	Modem II	FSK	300 Baud	-	NO	Modem IIIa ²
Radionics	2300Hz	1800Hz	40bps	3/1,4/2	NO	2300Hz
Radionics	2300Hz	1800Hz	40bps	4/2,3/1	YES	2300Hz
Radionics	2300Hz	1800Hz	40bps	3/1+parity	NO 4/2+parity	2300Hz
Radionics	2300Hz	1800Hz	40bps	3/1+parity, 4/2+parity	YES	2300Hz
Radionics BFSK	1400Hz	FSK	42 Baud	3/2	NO	1400Hz
Radionics BFSK	2300Hz	FSK	42 Baud	3/2	NO	2300Hz
S.F. Ademco	Dual Tone	DTMF	DTMF	4/8/1	NO	1400Hz
S.F. Ademco	Dual Tone	DTMF	DTMF	4/8/1 + Checksum	NO	1400Hz
Sescoa S. Speed	2300Hz	1800Hz	40bps	4/3+Checksum	NO	2300Hz
Sescoa S. Speed	2300Hz	1800Hz	40bps	4/3+Checksum	ID O/C	2300Hz
SIA FSK Level 1, 2, and 3.	SIA	FSK	110bps/300bps	-	-	tonal, data ACK
Silent Knight Fast	1400Hz	1900Hz	14bps	3/1,4/1 (or 3/2), 4/2	NO	1400Hz
Silent Knight Fast	1400Hz	1900Hz	14bps	4/2,4/1,3/1	YES	1400Hz
Silent Knight FSK 0	1400/2300Hz	FSK	110 Baud	4/1	NO	1400/2300Hz
Silent Knight FSK1	2300Hz	FSK	110 Baud	4/2, 5/2, 6/2	NO	2300Hz
Silent Knight FSK1	1400/2300Hz	FSK	100 Baud	4/2	NO	1400/2300Hz
Silent Knight FSK2	2300Hz	FSK	110 Baud	SIA equiv.	NO	2300Hz
Silent Knight FSK2	1400/2300Hz	FSK	100 Baud	4/2	NO	1400/2300Hz
Sur-Gard	2300Hz	DTMF	DTMF	4/1,4/2,4/3	NO	2300Hz
Sur-Gard	Dual Tone	DTMF	DTMF	4/1,4/2,4/3	NO	1400Hz
Sur-Gard	2300Hz	DTMF	DTMF	4/3+Checksum	NO	2300Hz
Sur-Gard	Dual Tone	DTMF	DTMF	4/3+Checksum	NO	1400Hz
DMP Serial 1**	DMP	FSK	300 Baud	DMP	NO	DMP
DMP Serial 3**	DMP	FSK	300 Baud	DMP	NO	DMP
Varitech	2300Hz	FSK	110 Baud	4/1,4/2	NO	2300Hz
Scantronics	1400Hz, Dual Tone	DTMF	DTMF	4/8/1,4/16/1,2/8/1,3/8/1 6/8/1,6/16/1,2/16/1,3/16/1	NO	1400Hz
Adcor	2300Hz	Pulse	Pulse	3/1,3/2	NO	2300Hz
Westec 1,2,3,5,6	Westec	DTMF	DTMF	Westec	NO	Westec
Surtec *	Surtec	DTMF	DTMF	Surtec	NO	Surtec
CFSK Type 1*	CFSK	FSK	300 Baud	CFSK	NO	CFSK
CFSK Type 2*	CFSK	FSK	300 Baud	CFSK	NO	CFSK
CFSK Type 4*	CFSK	FSK	300 Baud	CFSK	NO	CFSK
VONK *	FSK	FSK	110bps	4/5,4/8,4/16	NO	FSK
Robofon *	Robofon	1000Hz	50bps	6/2	NO	Robofon
Outel *	1600Hz	1600Hz	10bps	2/1	NO	1600Hz
FSK 200 baud *	FSK 200	FSK	200bps	5/3	NO	FSK
Stratel *	1800Hz (3s)	DTMF	DTMF	DTMF	NO	1000 Hz (2s)
DTMF 4-2 Checksum *	1400Hz/2300Hz	DTMF	DTMF	4/2 + checksum	NO	1400/2300Hz

* **NOTE:** Format Not UL Listed.

* **NOTE:** DMP is not supported by the SG-DRL3-2L.

IMPORTANT - READ CAREFULLY:

DSC Software purchased with or without Products and Components is copyrighted and is purchased under the following license terms:

- This End-User License Agreement (“EULA”) is a legal agreement between **You** (the company, individual or entity who acquired the Software and any related Hardware) and **Digital Security Controls, a division of Tyco Safety Products Canada Ltd.** (“DSC”), the manufacturer of the integrated security systems and the developer of the software and any related products or components (“HARDWARE”) which You acquired.
- If the DSC software product (“SOFTWARE PRODUCT” or “SOFTWARE”) is intended to be accompanied by HARDWARE, and is NOT accompanied by new HARDWARE, You may not use, copy or install the SOFTWARE PRODUCT. The SOFTWARE PRODUCT includes computer software, and may include associated media, printed materials, and “online” or electronic documentation.
- Any software provided along with the SOFTWARE PRODUCT that is associated with a separate end-user license agreement is licensed to You under the terms of that license agreement.
- By installing, copying, downloading, storing, accessing or otherwise using the SOFTWARE PRODUCT, You agree unconditionally to be bound by the terms of this EULA, even if this EULA is deemed to be a modification of any previous arrangement or contract. If You do not agree to the terms of this EULA, DSC is unwilling to license the SOFTWARE PRODUCT to You, and You have no right to use it.

SOFTWARE PRODUCT LICENSE

The SOFTWARE PRODUCT is protected by copyright laws and international copyright treaties, as well as other intellectual property laws and treaties. The SOFTWARE PRODUCT is licensed, not sold.

1. GRANT OF LICENSE This EULA grants You the following rights:

- (a) **Software Installation and Use** - For each license You acquire, You may have only one copy of the SOFTWARE PRODUCT installed.
- (b) **Storage/Network Use** - The SOFTWARE PRODUCT may not be installed, accessed, displayed, run, shared or used concurrently on or from different computers, including a workstation, terminal or other digital electronic device (“Device”). In other words, if You have several workstations, You will have to acquire a license for each workstation where the SOFTWARE will be used.
- (c) **Backup Copy** - You may make back-up copies of the SOFTWARE PRODUCT, but You may only have one copy per license installed at any given time. You may use the back-up copy solely for archival purposes. Except as expressly provided in this EULA, You may not otherwise make copies of the SOFTWARE PRODUCT, including the printed materials accompanying the SOFTWARE.

2. DESCRIPTION OF OTHER RIGHTS AND LIMITATIONS

- (a) **Limitations on Reverse Engineering, Decompilation and Disassembly** - You may not reverse engineer, decompile, or disassemble the SOFTWARE PRODUCT, except and only to the extent that such activity is expressly permitted by applicable law notwithstanding this limitation. You may not make any changes or modifications to the Software, without the written permission of an officer of DSC. You may not remove any proprietary notices, marks or labels from the Software Product. You shall institute reasonable measures to ensure compliance with the terms and conditions of this EULA.
- (b) **Separation of Components** - The SOFTWARE PRODUCT is licensed as a single product. Its component parts may not be separated for use on more than one HARDWARE unit.
- (c) **Single INTEGRATED PRODUCT** - If You acquired this SOFTWARE with HARDWARE, then the SOFTWARE PRODUCT is licensed with the HARDWARE as a single integrated product. In this case, the SOFTWARE PRODUCT may only be used with the HARDWARE as set forth in this EULA..
- (d) **Rental** - You may not rent, lease or lend the SOFTWARE PRODUCT. You may not make it available to others or post it on a server or web site.
- (e) **Software Product Transfer** - You may transfer all of Your rights under this EULA only as part of a permanent sale or transfer of the HARDWARE, provided You retain no copies, You transfer all of the SOFTWARE PRODUCT (including all component parts, the media and printed materials, any upgrades and this EULA), and provided the recipient agrees to the terms of this EULA. If the SOFTWARE PRODUCT is an upgrade, any transfer must also include all prior versions of the SOFTWARE PRODUCT.
- (f) **Termination** - Without prejudice to any other rights, DSC may terminate this EULA if You fail to comply with the terms and conditions of this EULA. In such event, You must destroy all copies of the SOFTWARE PRODUCT and all of its component parts.
- (g) **Trademarks** - This EULA does not grant You any rights in connection with any trademarks or service marks of DSC or its suppliers.

3. **COPYRIGHT** - All title and intellectual property rights in and to the SOFTWARE PRODUCT (including but not limited to any images, photographs, and text incorporated into the SOFTWARE PRODUCT), the accompanying printed materials, and any copies of the SOFTWARE PRODUCT, are owned by DSC or its suppliers. You may not copy the printed materials accompanying the SOFTWARE PRODUCT. All title and intellectual property rights in and to the content which may be accessed through use of the SOFTWARE PRODUCT are the property of the respective content owner and may be protected by applicable copyright or other intellectual property laws and treaties. This EULA grants You no rights to use such content. All rights not expressly granted under this EULA are reserved by DSC and its suppliers.

4. **EXPORT RESTRICTIONS** - You agree that You will not export or re-export the SOFTWARE PRODUCT to any country, person, or entity subject to Canadian export restrictions.

5. **CHOICE OF LAW** - This Software License Agreement is governed by the laws of the Province of Ontario, Canada.

6. **ARBITRATION** - All disputes arising in connection with this Agreement shall be determined by final and binding arbitration in accordance with the Arbitration Act, and the parties agree to be bound by the arbitrator’s decision. The place of arbitration shall be Toronto, Canada, and the language of the arbitration shall be English.

7. **LIMITED WARRANTY**

(a) **NO WARRANTY** - DSC PROVIDES THE SOFTWARE “AS IS” WITHOUT WARRANTY. DSC DOES NOT WARRANT THAT THE SOFTWARE WILL MEET YOUR REQUIREMENTS OR THAT OPERATION OF THE SOFTWARE WILL BE UNINTERRUPTED OR ERROR-FREE.

(b) **CHANGES IN OPERATING ENVIRONMENT** - DSC shall not be responsible for problems caused by changes in the operating characteristics of the HARDWARE, or for problems in the interaction of the SOFTWARE PRODUCT with non-DSC-SOFTWARE or HARDWARE PRODUCTS.

(c) **LIMITATION OF LIABILITY; WARRANTY REFLECTS ALLOCATION OF RISK** - IN ANY EVENT, IF ANY STATUTE IMPLIES WARRANTIES OR CONDITIONS NOT STATED IN THIS LICENSE AGREEMENT, DSC’S ENTIRE LIABILITY UNDER ANY PROVISION OF THIS LICENSE AGREEMENT SHALL BE LIMITED TO THE GREATER OF THE AMOUNT ACTUALLY PAID BY YOU TO LICENSE THE SOFTWARE PRODUCT AND FIVE CANADIAN DOLLARS (CAD\$5.00). BECAUSE SOME JURISDICTIONS DO NOT ALLOW THE EXCLUSION OR LIMITATION OF LIABILITY FOR CONSEQUENTIAL OR INCIDENTAL DAMAGES, THE ABOVE LIMITATION MAY NOT APPLY TO YOU.

(d) **DISCLAIMER OF WARRANTIES** - THIS WARRANTY CONTAINS THE ENTIRE WARRANTY AND SHALL BE IN LIEU OF ANY AND ALL OTHER WARRANTIES, WHETHER EXPRESSED OR IMPLIED (INCLUDING ALL IMPLIED WARRANTIES OF MERCHANTABILITY OR FITNESS FOR A PARTICULAR PURPOSE) AND OF ALL OTHER OBLIGATIONS OR LIABILITIES ON THE PART OF DSC. DSC MAKES NO OTHER WARRANTIES. DSC NEITHER ASSUMES NOR AUTHORIZES ANY OTHER PERSON PURPORTING TO ACT ON ITS BEHALF TO MODIFY OR TO CHANGE THIS WARRANTY, NOR TO ASSUME FOR IT ANY OTHER WARRANTY OR LIABILITY CONCERNING THIS SOFTWARE PRODUCT.

(e) **EXCLUSIVE REMEDY AND LIMITATION OF WARRANTY** - UNDER NO CIRCUMSTANCES SHALL DSC BE LIABLE FOR ANY SPECIAL, INCIDENTAL, CONSEQUENTIAL OR INDIRECT DAMAGES BASED UPON BREACH OF WARRANTY, BREACH OF CONTRACT, NEGLIGENCE, STRICT LIABILITY, OR ANY OTHER LEGAL THEORY. SUCH DAMAGES INCLUDE, BUT ARE NOT LIMITED TO, LOSS OF PROFITS, LOSS OF THE SOFTWARE PRODUCT OR ANY ASSOCIATED EQUIPMENT, COST OF CAPITAL, COST OF SUBSTITUTE OR REPLACEMENT EQUIPMENT, FACILITIES OR SERVICES, DOWN TIME, PURCHASERS TIME, THE CLAIMS OF THIRD PARTIES, INCLUDING CUSTOMERS, AND INJURY TO PROPERTY. **WARNING: DSC recommends that the entire system be completely tested on a regular basis. However, despite frequent testing, and due to, but not limited to, criminal tampering or electrical disruption, it is possible for this SOFTWARE PRODUCT to fail to perform as expected.**

FCC Compliance Statement

CAUTION: Changes or modifications not expressly approved by Digital Security Controls could void your authority to use this equipment.

This equipment has been tested and found to comply with the limits for a Class B digital device, pursuant to Part 15 of the FCC Rules. These limits are designed to provide reasonable protection against harmful interference in a residential installation. This equipment generates, uses and can radiate radio frequency energy and, if not installed and used in accordance with the instructions, may cause harmful interference to radio communications. However, there is no guarantee that interference will not occur in a particular installation. If this equipment does cause harmful interference to radio or television reception, which can be determined by turning the equipment off and on, the user is encouraged to try to correct the interference by one or more of the following measures:

- Re-orient the receiving antenna.
- Increase the separation between the equipment and receiver.
- Connect the equipment into an outlet on a circuit different from that to which the receiver is connected.
- Consult the dealer or an experienced radio/television technician for help.

The user may find the following booklet prepared by the FCC useful: "How to Identify and Resolve Radio/Television Interference Problems". This booklet is available from the U.S. Government Printing Office, Washington D.C. 20402, Stock # 004-000-00345-4.

Important Information

This equipment complies with Part 68 of the FCC Rules and the requirements adopted by the ACTA. On the side of this equipment is a label that contains, among other information, a product identifier in the format US:AAAEQ##TXXXX. If requested, this number must be provided to the Telephone Company.

SG-DRL3 Line Card

Product Identifier: US:F53AL03BSYSTEMIII

SG-DRL3-2L

Product Identifier: US:F53AL02BDRL342L

USOC Jack: RJ-21X

Telephone Connection Requirements

A plug and jack used to connect this equipment to the premises wiring and telephone network must comply with the applicable FCC Part 68 rules and requirements adopted by the ACTA. A compliant telephone cord and modular plug is provided with this product. It is designed to be connected to a compatible modular jack that is also compliant. See installation instructions for details.

Ringer Equivalence Number (REN) The REN is used to determine the number of devices that may be connected to a telephone line. Excessive RENs on a telephone line may result in the devices not ringing in response to an incoming call. In most but not all areas, the sum of RENs should not exceed five (5.0). To be certain of the number of devices that may be connected to a line, as determined by the total RENs, contact the local Telephone Company. For products approved after July 23, 2001, the REN for this product is part of the product identifier that has the format.

US: AAAEQ##TXXXX. The digits represented by ## are the REN without a decimal point

Industry Canada Statement

SG-DRL3 IC:160A-SYSTEM3

SG-DRL3-2L IC:160A-DRL342L

NOTICE: This equipment meets the applicable Industry Canada Terminal Equipment Technical Specifications. This is confirmed by the registration number. The abbreviation, IC, before the registration number signifies that registration was performed based on a Declaration of Conformity indicating that Industry Canada technical specifications were met. It does not imply that Industry Canada approved the equipment.

NOTICE: The Ringer Equivalence Number (REN) for this terminal is 01 when using line card model SG-DRL3, or 02 when using line card Model SG-DRL3-2L. The REN assigned to each terminal equipment provides an indication of the maximum number of terminals allowed to be connected to a telephone interface. The termination on an interface may consist of any combination of devices subject only to the requirement that the sum of the Ringer Equivalence Numbers of all the devices does not exceed five.

L'indice d'équivalence de la sonnerie (IES) sert à indiquer le nombre maximal de terminaux qui peuvent être raccordés à une interface téléphonique. La terminaison d'une interface peut consister en une combinaison quelconque de dispositifs, à la seule condition que la somme d'indices d'équivalence de la sonnerie de tous les dispositifs n'exécède pas 5.

The trademarks, logos, and service marks displayed on this document are registered in the United States [or other countries]. Any misuse of the trademarks is strictly prohibited and Tyco International Ltd. will aggressively enforce its intellectual property rights to the fullest extent of the law, including pursuit of criminal prosecution wherever necessary. All trademarks not owned by Tyco International Ltd. are the property of their respective owners, and are used with permission or allowed under applicable laws.

Product offerings and specifications are subject to change without notice. Actual products may vary from photos. Not all products include all features. Availability varies by region; contact your sales representative.

(e.g., 03 is a REN of 0.3). For earlier products, the REN is separately shown on the label.

Incidence of Harm If this equipment Sur-Gard SYSTEM III causes harm to the telephone network, the telephone company will notify you in advance that temporary discontinuance of service may be required. But if advance notice is not practical, the Telephone Company will notify the customer as soon as possible. Also, you will be advised of your right to file a complaint with the FCC if you believe it is necessary.

Changes in Telephone Company Equipment or Facilities The Telephone Company may make changes in its facilities, equipment, operations or procedures that could affect the operation of the equipment. If this happens the Telephone Company will provide advance notice in order for you to make necessary modifications to maintain uninterrupted service.

Equipment Maintenance Facility If trouble is experienced with this equipment Sur-Gard SYSTEM III, for repair or warranty information, please contact the facility indicated below. If the equipment is causing harm to the telephone network, the Telephone Company may request that you disconnect the equipment until the problem is solved. This equipment is of a type that is not intended to be repaired by the end user.

DSC c/o APL Logistics

757 Douglas Hill Rd

Lithia Springs, GA, 30122 U.S.A.

Additional Information Connection to party line service is subject to state tariffs. Contact the state public utility commission, public service commission or corporation commission for information.

Alarm dialing equipment must be able to seize the telephone line and place a call in an emergency situation. It must be able to do this even if other equipment (telephone, answering system, computer modem, etc.) already has the telephone line in use. To do so, alarm dialing equipment must be connected to a properly installed RJ31X jack that is electrically in series with and ahead of all other equipment attached to the same telephone line. Proper installation is depicted in the figure below. If you have any questions concerning these instructions, you should consult your telephone company or a qualified installer about installing the RJ31X jack and alarm dialing equipment for you.

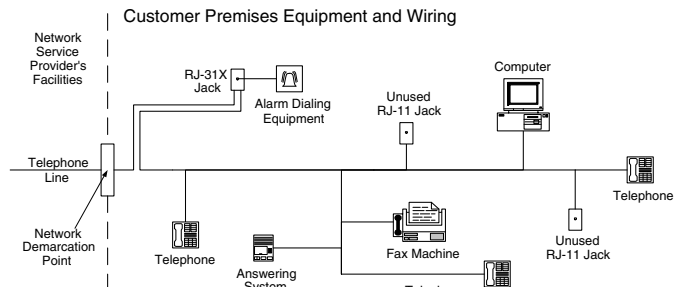

Hereby, DSC, declares that this device is in compliance with the essential requirements and other relevant provisions of Directive 1999/5/EC. The complete R&TTE Declaration of Conformity can be found at http://www.dsc.com/listings_index.aspx

(CZE) DSC jako výrobce prohlašuje, že tento výrobek je v souladu se všemi relevantními požadavky směrnice 1999/5/EC.

(DAN) DSC erklærer herved at denne komponent overholder alle vigtige krav samt andre bestemmelser gældende i direktiv 1999/5/EC.

(DUT) Hierbij verklaart DSC dat dit toestel in overeenstemming is met de eisen en bepalingen van richtlijn 1999/5/EC.

(FIN) DSC vakuuttaa laitteen täyttävän direktiivin 1999/5/EC olennaiset vaatimukset.

(FRE) Par la présente, DSC déclare que ce dispositif est conforme aux exigences essentielles et autres dispositions pertinentes de la Directive 1999/5/EC.

(GER) Hierdurch erklärt DSC, daß dieses Gerät den erforderlichen Bedingungen und Voraussetzungen der Richtlinie 1999/5/EC entspricht.

(GRE) Διο του παρόντος, η DSC δηλώνει ότι αυτή η συσκευή είναι σύμφωνη με τις ουσιαστικές απαιτήσεις και με όλες τις άλλες σχετικές αναφορές της Οδηγίας 1999/5/EC.

(ITA) Con la presente la Digital Security Controls dichiara che questo prodotto è conforme ai requisiti essenziali ed altre disposizioni rilevanti relative alla Direttiva 1999/05/CE.

(NOR) DSC erklærer at denne enheten er i samsvar med de grunnleggende krav og øvrige relevante krav i direktiv 1999/5/EF.

(POL) DSC oświadcza, że urządzenie jest w zgodności z zasadniczymi wymaganiami oraz pozostałymi stosownymi postanowieniami Dyrektywy 1999/5/WE.

(POR) Por este meio, a DSC, declara que este equipamento está em conformidade com os requisitos essenciais e outras determinações relevantes da Directiva 1999/5/EC.

(SPA) Por la presente, DSC, declara que este equipo está en conformidad con los requisitos esenciales y otros requisitos relevantes de la Directiva 1999/5/EC.

(SWE) DSC bekräftar härmed att denna apparat uppfyller de väsentliga kraven och andra relevanta bestämmelser i Direktivet 1999/5/EC.

DSC
A Tyco International Company

©2010 Tyco International Ltd. and its Respective Companies.
All Rights Reserved. • www.dsc.com
Sales: 1-888-888-7838
Tech. Support (Canada & USA): 1-800-503-5869
Printed in Canada

